



SLRC610

High performance ISO/IEC 15693 reader solution

Rev. 3.4 — 6 February 2014
227634

Product data sheet
COMPANY PUBLIC

1. Introduction

This document describes the functionality and electrical specifications of the contactless reader/writer IC SLRC610.

2. General description

The SLRC610 is a highly integrated transceiver IC for contactless communication at 13.56 MHz.

The SLRC610 transceiver IC supports the following operating modes

- Read/write mode supporting ISO/IEC 15693
- Read/write mode supporting ICODE EPC UID/ EPC OTP
- Read/write mode supporting ISO/IEC 18000-3 mode 3/ EPC Class-1 HF

The SLRC610 supports the vicinity protocol according to ISO/IEC15693, EPC UID and ISO/IEC 18000-3 mode 3/ EPC Class-1 HF.

The following host interfaces are supported:

- Serial Peripheral Interface (SPI)
- Serial UART (similar to RS232 with voltage levels dependent on pin voltage supply)
- I²C-bus interface (two versions are implemented: I2C and I2CL)

The SLRC610 supports the connection of a secure access module (SAM). A dedicated separate I2C interface is implemented for a connection of the SAM. The SAM can be used for high secure key storage and acts as a very performant crypto coprocessor. A dedicated SAM is available for connection to the SLRC610.

3. Features and benefits

- High RF output power frontend IC
- Supports ISO/IEC15693, ICODE EPC UID and ISO/IEC 18000-3 mode 3/ EPC Class-1 HF
- Low-Power Card Detection
- Antenna connection with minimum number of external components
- Supported host interfaces:
 - ◆ SPI up to 10 Mbit/s
 - ◆ I²C-bus interfaces up to 400 kBd in Fast mode, up to 1000 kBd in Fast mode plus



- ◆ RS232 Serial UART up to 1228.8 kBd, with voltage levels dependent on pin voltage supply
- Separate I²C-bus interface for connection of a secure access module (SAM)
- FIFO buffer with size of 512 byte for highest transaction performance
- Flexible and efficient power saving modes including hard power down, standby and low-power card detection
- Cost saving by integrated PLL to derive system CPU clock from 27.12 MHz RF quartz crystal
- 3 V to 5.5 V power supply
- Up to 8 free programmable input/output pins

4. Quick reference data

Table 1. Quick reference data

| Symbol | Parameter | Conditions | Min | Typ | Max | Unit |
|-----------------------|---------------------|---------------------------|----------|-----|-----------------|------|
| V _{DD} | supply voltage | | 3 | 5 | 5.5 | V |
| V _{DD(PVDD)} | PVDD supply voltage | | [1] 3 | 5 | V _{DD} | V |
| V _{DD(TVDD)} | TVDD supply voltage | | 3 | 5 | 5.5 | V |
| I _{pd} | power-down current | PDOWN pin pulled HIGH | [2] - | 8 | 40 | nA |
| I _{DD} | supply current | | - | 17 | 20 | mA |
| I _{DD(TVDD)} | TVDD supply current | | [3][4] - | 100 | 200 | mA |
| T _{amb} | ambient temperature | | -25 | +25 | +85 | °C |
| T _{stg} | storage temperature | no supply voltage applied | -40 | +25 | +100 | °C |

[1] V_{DD(PVDD)} must always be the same or lower voltage than V_{DD}.

[2] I_{pd} is the sum of all supply currents

[3] I_{DD(TVDD)} depends on V_{DD(TVDD)} and the external circuitry connected to TX1 and TX2.

[4] Typical value: Assumes the usage of a complementary driver configuration and an antenna matched to 40 Ω between pins TX1, TX2 at 13.56 MHz.

5. Ordering information

Table 2. Ordering information

| Type number | Package | | Version |
|-----------------------|---------|---|----------|
| | Name | Description | |
| SLRC61002HN/TRAYB[1] | HVQFN32 | plastic thermal enhanced very thin quad flat package; no leads; MSL1, 32 terminals + 1 central ground; body 5 × 5 × 0.85 mm | SOT617-1 |
| SLRC61002HN/TRAYBM[2] | | | |
| SLRC61002HN/T/R[3] | | | |

[1] Delivered in one tray

[2] Delivered in five trays

[3] Delivered on reel with 6000 pieces

6. Block diagram

The analog interface handles the modulation and demodulation of the antenna signals for the contactless interface.

The contactless UART manages the protocol dependency of the contactless interface settings managed by the host.

The FIFO buffer ensures fast and convenient data transfer between host and the contactless UART.

The register bank contains the settings for the analog and digital functionality.

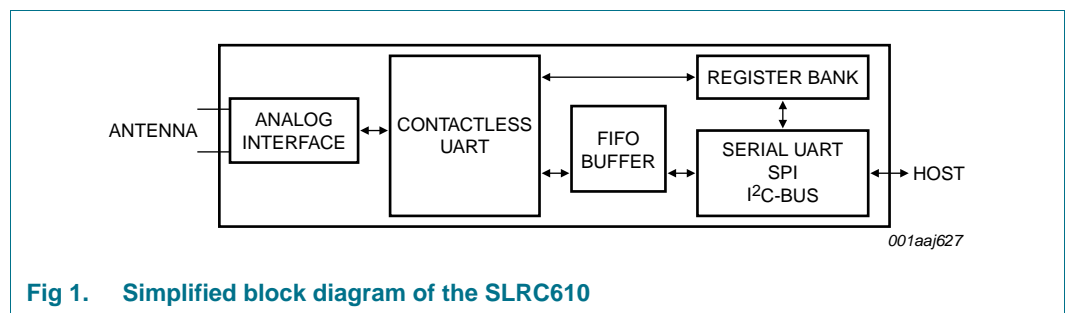

Fig 1. Simplified block diagram of the SLRC610

7. Pinning information

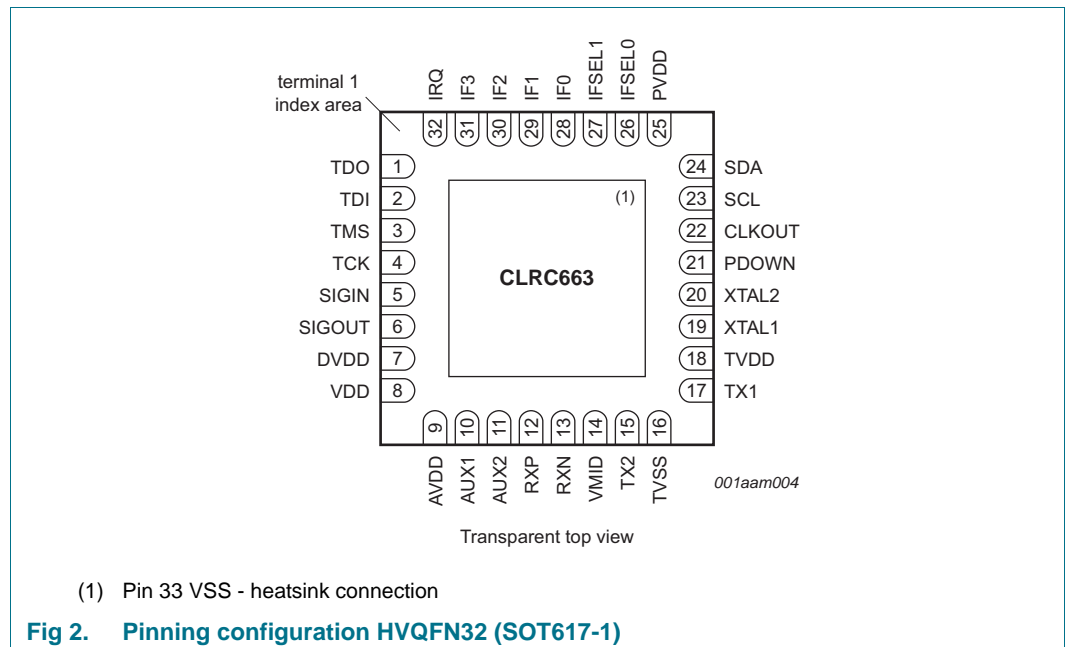

Fig 2. Pinning configuration HVQFN32 (SOT617-1)

7.1 Pin description

Table 3. Pin description

| Pin | Symbol | Type | Description |
|-----|--------|------|---|
| 1 | TDO | O | test data output for boundary scan interface |
| 2 | TDI | I | test data input boundary scan interface |
| 3 | TMS | I | test mode select boundary scan interface |
| 4 | TCK | I | test clock boundary scan interface |
| 5 | SIGIN | I | Contactless communication interface output. |
| 6 | SIGOUT | O | Contactless communication interface input. |
| 7 | DVDD | PWR | digital power supply buffer [1] |
| 8 | VDD | PWR | power supply |
| 9 | AVDD | PWR | analog power supply buffer [1] |
| 10 | AUX1 | O | auxiliary outputs: Pin is used for analog test signal |
| 11 | AUX2 | O | auxiliary outputs: Pin is used for analog test signal |
| 12 | RXP | I | receiver input pin for the received RF signal. |
| 13 | RXN | I | receiver input pin for the received RF signal. |
| 14 | VMID | PWR | internal receiver reference voltage [1] |
| 15 | TX2 | O | transmitter 2: delivers the modulated 13.56 MHz carrier |
| 16 | TVSS | PWR | transmitter ground, supplies the output stage of TX1, TX2 |
| 17 | TX1 | O | transmitter 1: delivers the modulated 13.56 MHz carrier |
| 18 | TVDD | PWR | transmitter voltage supply |
| 19 | XTAL1 | I | crystal oscillator input: Input to the inverting amplifier of the oscillator. This pin is also the input for an externally generated clock (fosc = 27,12 MHz) |
| 20 | XTAL2 | O | crystal oscillator output: output of the inverting amplifier of the oscillator |
| 21 | PDOWN | I | Power Down |
| 22 | CLKOUT | O | clock output |
| 23 | SCL | O | Serial Clock line |
| 24 | SDA | I/O | Serial Data Line |
| 25 | PVDD | PWR | pad power supply |
| 26 | IFSEL0 | I | host interface selection 0 |
| 27 | IFSEL1 | I | host interface selection 1 |
| 28 | IF0 | I/O | interface pin, multifunction pin: Can be assigned to host interface RS232, SPI, I ² C, I ² C-L |
| 29 | IF1 | I/O | interface pin, multifunction pin: Can be assigned to host interface SPI, I ² C, I ² C-L |
| 30 | IF2 | I/O | interface pin, multifunction pin: Can be assigned to host interface RS232, SPI, I ² C, I ² C-L |
| 31 | IF3 | I/O | interface pin, multifunction pin: Can be assigned to host interface RS232, SPI, I ² C, I ² C-L |
| 32 | IRQ | O | interrupt request: output to signal an interrupt event |
| 33 | VSS | PWR | ground and heatsink connection |

[1] This pin is used for connection of a buffer capacitor. Connection of a supply voltage might damage the device.

8. Functional description

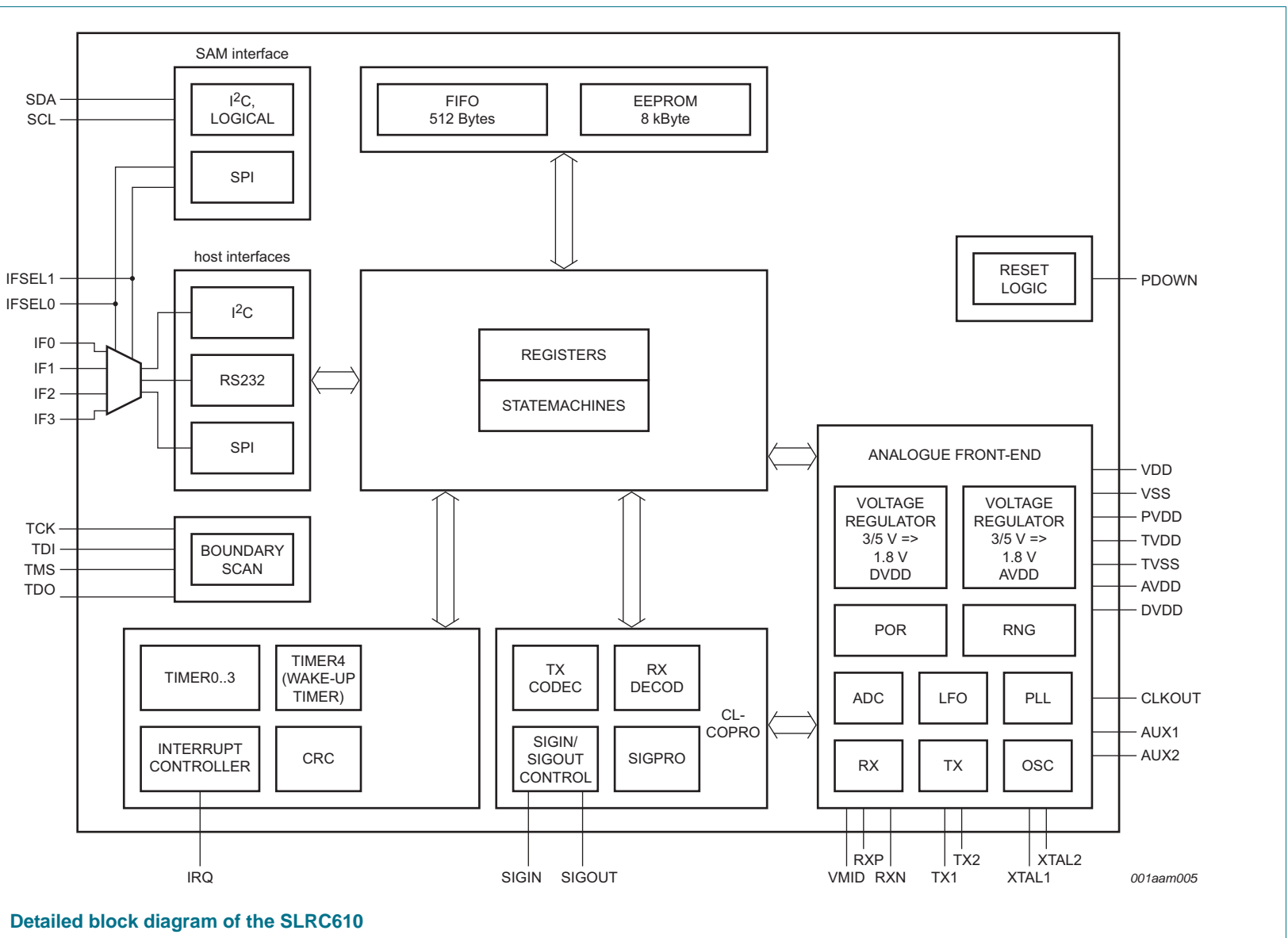

Fig 3. Detailed block diagram of the SLRC610

8.1 Interrupt controller

The interrupt controller handles the enabling/disabling of interrupt requests. All of the interrupts can be configured by firmware. Additionally, the firmware has possibilities to trigger interrupts or clear pending interrupt requests. Two 8-bit interrupt registers IRQ0 and IRQ1 are implemented, accompanied by two 8-bit interrupt enable registers IRQ0En and IRQ1En. A dedicated functionality of bit 7 to set and clear bits 0 to 6 in this interrupt controller registers is implemented.

The SLRC610 indicates certain events by setting bit IRQ in the register Status1Reg and additionally, if activated, by pin IRQ. The signal on pin IRQ may be used to interrupt the host using its interrupt handling capabilities. This allows the implementation of efficient host software.

The following table shows the available interrupt bits, the corresponding source and the condition for its activation. The interrupt bit Timernlrq in register IRQ1 indicates an interrupt set by the timer unit. The setting is done if the timer underflows.

The TxIrq bit in register IRq0 indicates that the transmission is finished. If the state changes from sending data to transmitting the end of the frame pattern, the transmitter unit sets the interrupt bit automatically.

The bit RxIrq in register IRQ0 indicates an interrupt when the end of the received data is detected.

The bit IdleIrq in register IRQ0 is set if a command finishes and the content of the command register changes to idle.

The waterlevel defines both - minimum and maximum warning levels - counting from top and from bottom of the FIFO by a single value.

The bit HiAlertIrq in register IRQ0 is set to logic 1 if the HiAlert bit is set to logic 1, that means the FIFO data number has reached the top level as configured by the bit WaterLevel.

The bit LoAlertIrq in register IRQ0 is set to logic 1 if the LoAlert bit is set to logic 1, that means the FIFO data number has reached the bottom level as configured by the bit WaterLevel.

The bit Errlrq in register IRQ0 indicates an error detected by the contactless UART during receive. This is indicated by any bit set to logic 1 in register Error.

The bit LPCDIrq in register IRQ0 indicates a card detected.

The bit RxSOFIrq in register IRQ0 indicates a detection of a SOF or a subcarrier by the contactless UART during receiving.

The bit GlobalIrq in register IRQ1 indicates an interrupt occurring at any other interrupt source when enabled.

Table 4. Interrupt sources

| Interrupt bit | Interrupt source | Is set automatically, when |
|---------------|-----------------------|---|
| Timer0Irq | Timer Unit | the timer register T0 CounterVal underflows |
| Timer1Irq | Timer Unit | the timer register T1 CounterVal underflows |
| Timer2Irq | Timer Unit | the timer register T2 CounterVal underflows |
| Timer3Irq | Timer Unit | the timer register T3 CounterVal underflows |
| TxIrq | Transmitter | a transmitted data stream ends |
| RxIrq | Receiver | a received data stream ends |
| IdleIrq | Command Register | a command execution finishes |
| HiAlertIrq | FIFO-buffer pointer | the FIFO data number has reached the top level as configured by the bit WaterLevel |
| LoAlertIrq | FIFO-buffer pointer | the FIFO data number has reached the bottom level as configured by the bit WaterLevel |
| ErrIrq | contactless UART | a communication error had been detected |
| LPCDIrq | LPCD | a card was detected when in low-power card detection mode |
| RxSOFIrq | Receiver | detection of a SOF or a subcarrier |
| Globallrq | all interrupt sources | will be set if another interrupt request source is set |

8.2 Timer module

Timer module overview

The SLRC610 implements five timers. Four timers -Timer0 to Timer3 - have an input clock that can be configured by register T(x)Control to be 13.56 MHz, 212 kHz, (derived from the 27.12 MHz quartz) or to be the underflow event of the fifth Timer (Timer4). Each timer implements a counter register which is 16 bit wide. A reload value for the counter is defined in a range of 0000h to FFFFh in the registers TxReloadHi and TxReloadLo. The fifth timer Timer4 is intended to be used as a wakeup timer and is connected to the internal LFO (Low Frequency Oscillator) as input clock source.

The TControl register allows the global start and stop of each of the four timers Timer0 to Timer3. Additionally, this register indicates if one of the timers is running or stopped. Each of the five timers implements an individual configuration register set defining timer reload value (e.g. T0ReloadHi,T0ReloadLo), the timer value (e.g. T0CounterValHi, T0CounterValLo) and the conditions which define start, stop and clockfrequency (e.g. T0Control).

The external host may use these timers to manage timing relevant tasks. The timer unit may be used in one of the following configurations:

- Time-out counter
- Watch-dog counter
- Stop watch
- Programmable one-shot timer
- Periodical trigger

The timer unit can be used to measure the time interval between two events or to indicate that a specific event has occurred after an elapsed time. The timer register content is modified by the timer unit, which can be used to generate an interrupt to allow an host to react on this event.

The counter value of the timer is available in the registers T(x)CounterValHi, T(x)CounterValLo. The content of these registers is decremented at each timer clock.

If the counter value has reached a value of 0000h and the interrupts are enabled for this specific timer, an interrupt will be generated as soon as the next clock is received.

If enabled, the timer event can be indicated on the pin IRQ (interrupt request). The bit Timer(x)Irq can be set and reset by the host controller. Depending on the configuration, the timer will stop counting at 0000h or restart with the value loaded from registers T(x)ReloadHi, T(x)ReloadLo.

The counting of the timer is indicated by bit TControl.T(x)Running.

The timer can be started by setting bits TControl.T(x)Running and TControl.T(x)StartStopNow or stopped by setting the bits TControl.T(x)StartStopNow and clearing TControl.T(x)Running.

Another possibility to start the timer is to set the bit T(x)Mode.T(x)Start, this can be useful if dedicated protocol requirements need to be fulfilled.

8.2.1 Timer modes

8.2.1.1 Time-Out- and Watch-Dog-Counter

Having configured the timer by setting *register* $T(x)ReloadValue$ and starting the counting of Timer(x) by setting bit TControl.T(x)StartStop and TControl.T(x)Running, the timer unit decrements the $T(x)CounterValue$ Register beginning with the configured start event. If the configured stop event occurs before the Timer(x) underflows (e.g. a bit is received from the card), the timer unit stops (no interrupt is generated).

If no stop event occurs, the timer unit continues to decrement the counter registers until the content is zero and generates a timer interrupt request at the next clock cycle. This allows to indicate to a host that the event did not occur during the configured time interval.

8.2.1.2 Wake-up timer

The wake-up Timer4 allows to wakeup the system from standby after a predefined time. The system can be configured in such a way that it is entering the standby mode again in case no card had been detected.

This functionality can be used to implement a low-power card detection (LPCD). For the low-power card detection it is recommended to set T4Control.T4AutoWakeUp and T4Control.T4AutoRestart, to activate the Timer4 and automatically set the system in standby. The internal low frequency oscillator (LFO) is then used as input clock for this Timer4. If a card is detected the host-communication can be started. If bit T4Control.T4AutoWakeUp is not set, the SLRC610 will not enter the standby mode again in case no card is detected but stays fully powered.

8.2.1.3 Stop watch

The elapsed time between a configured start- and stop event may be measured by the SLRC610 timer unit. By setting the registers $T(x)ReloadValueHi$, $T(x)reloadValueLo$ the timer starts to decrement as soon as activated. If the configured stop event occurs, the timers stops decrementing. The elapsed time between start and stop event can then be calculated by the host dependent on the timer interval TTimer:

$$\Delta T = (T_{reload\ value} - Timer\ value) * T_{Timer} \quad (1)$$

If an underflow occurred which can be identified by evaluating the corresponding IRQ bit, the performed time measurement according to the formula above is not correct.

8.2.1.4 Programmable one-shot timer

The host configures the interrupt and the timer, starts the timer and waits for the interrupt event on pin IRQ. After the configured time the interrupt request will be raised.

8.2.1.5 Periodical trigger

If the bit $T(x)Control.T(x)AutoRestart$ is set and the interrupt is activated, an interrupt request will be indicated periodically after every elapsed timer period.

8.3 Contactless interface unit

The contactless interface unit of the SLRC610 supports the following read/write operating modes:

- ISO/IEC15693/ICODE
- ICODE EPC UID
- ISO/IEC 18000-3 mode 3/ EPC Class-1 HF

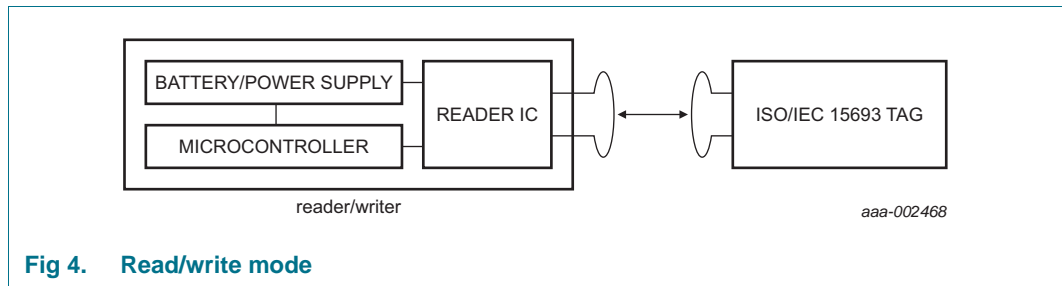

Fig 4. Read/write mode

A typical system using the SLRC610 is using a microcontroller to implement the higher levels of the contactless communication protocol and a power supply (battery or external supply).

8.3.1 ISO/IEC15693 functionality

The physical parameters are described in [Table 5](#).

Table 5. Communication overview for ISO/IEC 15693 reader/writer reader to label

| Communication direction | Signal type | Transfer speed | |
|--|------------------------|-------------------------------|------------------------------------|
| | | fc / 8192 kbit/s | fc / 512 kbit/s |
| Reader to label (send data from the SLRC610 to a card) | reader side modulation | 10 % to 30 % ASK or 100 % ASK | 10 % to 30 % ASK 90 % to 100 % ASK |
| | bit encoding | 1/256 | 1/4 |
| | data rate | 1,66 kbit/s | 26,48kbit/s |

Table 6. Communication overview for ISO/IEC 15693 reader/writer label to reader

| Communication direction | Signal type | Transfer speed | | | |
|--|----------------------------|--------------------|-----------------------------|--|---------------------------------------|
| | | 6.62 (6.67) kbit/s | 13.24 kbit/s ^[1] | 26.48 (26.69) kbit/s | 52.96 kbit/s |
| Label to reader (SLRC610 receives data from a card) fc = 13.56 MHz | card side modulation | not supported | not supported | single (dual) subcarrier load modulation ASK | single subcarrier load modulation ASK |
| | bit length (µs) | - | - | 37.76 (37.46) | 18.88 |
| | bit encoding | - | - | Manchester coding | Manchester coding |
| | subcarrier frequency [MHz] | - | - | fc / 32 (fc / 28) | fc / 32 |

[1] Fast inventory (page) read command only (ICODE proprietary command).

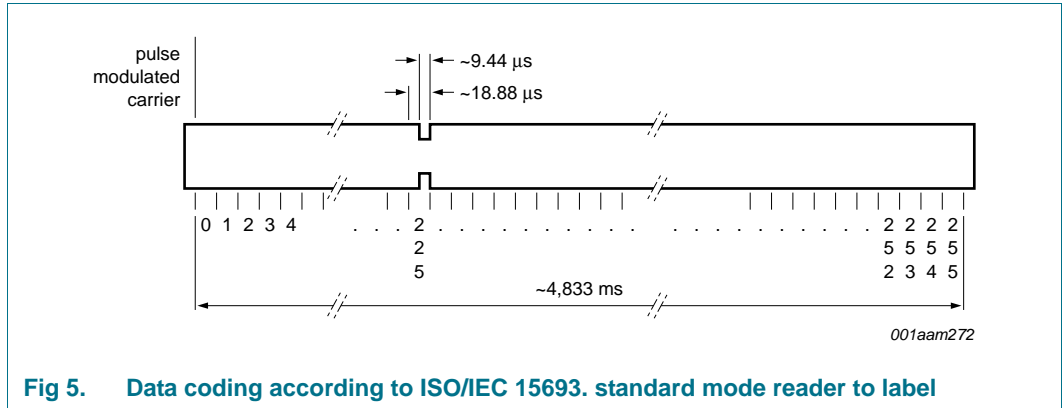

8.3.2 EPC-UID/UID-OTP functionality

The physical parameters are described in [Table 7](#).

Table 7. Communication overview for EPC/UID

| Communication direction | Signal type | Transfer speed | |
|---|------------------------|------------------|-----------------------------------|
| | | 26.48 kbit/s | 52.96 kbit/s |
| Reader to card (send data from the SLRC610 to a card) | reader side modulation | 10 % to 30 % ASK | |
| | bit encoding | RTZ | |
| | bit length | 37.76 μs | |
| Card to reader (SLRC610 receives data from a card) | card side modulation | | single subcarrier load modulation |
| | bit length | | 18.88 μs |
| | bit encoding | | Manchester coding |

Data coding and framing according to EPC global 13.56 MHz ISM (industrial, scientific and medical) Band Class 1 Radio Frequency Identification Tag Interface Specification (Candidate Recommendation, Version 1.0.0).

8.3.3 ISO/IEC 18000-3 mode 3/ EPC Class-1 HF functionality

The ISO/IEC 18000-3 mode 3/ EPC Class-1 HF is not described in this document. For a detailed explanation of the protocol, refer to the ISO/IEC 18000-3 mode 3/ EPC Class-1 HF standard.

8.3.4 EPC Class-1 HF and ICODE

8.3.4.1 Data encoding ICODE

The ICODE protocols have mainly three different methods of data encoding:

- “1” out of “4” coding scheme
- “1” out of “256” coding scheme
- “Return to Zero” (RZ) coding scheme

Data encoding for all three coding schemes is done by the ICODE generator.

The supported EPC Class-1 HF modes are:

- 2 pulse for 424 kbit subcarrier
- 4 pulse for 424 kbit subcarrier
- 2 pulse for 848 kbit subcarrier
- 4 pulse for 848 kbit subcarrier

8.4 Host interfaces

8.4.1 Host interface configuration

The SLRC610 supports direct interfacing of various hosts as the SPI, I²C, I²CL and serial UART interface type. The SLRC610 resets its interface and checks the current host interface type automatically having performed a power-up or resuming from power down. The SLRC610 identifies the host interface by the means of the logic levels on the control

pins after the Cold Reset Phase. This is done by a combination of fixed pin connections. The following table shows the possible configurations defined by IFSEL1, IFSEL0:

Table 8. Connection scheme for detecting the different interface types

| Pin | Pin Symbol | UART | SPI | I ² C | I ² C-L |
|-----|------------|------|------|------------------|--------------------|
| 28 | IF0 | RX | MOSI | ADR1 | ADR1 |
| 29 | IF1 | - | SCK | SCL | SCL |
| 30 | IF2 | TX | MISO | ADR2 | SDA |
| 31 | IF3 | 1 | NSS | SDA | ADR2 |
| 26 | IFSEL0 | 0 | 0 | 1 | 1 |
| 27 | IFSEL1 | 0 | 1 | 0 | 1 |

8.4.2 SPI interface

8.4.2.1 General

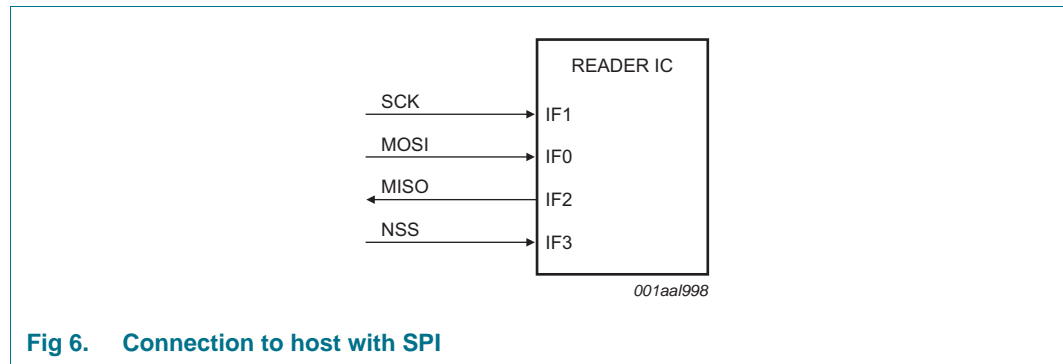

Fig 6. Connection to host with SPI

The SLRC610 acts as a slave during the SPI communication. The SPI clock SCK has to be generated by the master. Data communication from the master to the slave uses the Line MOSI. Line MISO is used to send data back from the SLRC610 to the master.

A serial peripheral interface (SPI compatible) is supported to enable high speed communication to a host. The implemented SPI compatible interface is according to a standard SPI interface. The SPI compatible interface can handle data speed of up to 10 Mbit/s. In the communication with a host SLRC610 acts as a slave receiving data from the external host for register settings and to send and receive data relevant for the communication on the RF interface.

On both data lines (MOSI, MISO) each data byte is sent by MSB first. Data on MOSI line shall be stable on rising edge of the clock line (SCK) and is allowed to change on falling edge. The same is valid for the MISO line. Data is provided by the SLRC610 on the falling edge and is stable on the rising edge. The polarity of the clock is low at SPI idle.

8.4.2.2 Read data

To read out data from the SLRC610 by using the SPI compatible interface the following byte order has to be used.

The first byte that is sent defines the mode (LSB bit) and the address.

Table 9. Byte Order for MOSI and MISO

| | byte 0 | byte 1 | byte 2 | byte 3 to n-1 | byte n | byte n+1 |
|------|-----------|-----------|-----------|---------------|------------|----------|
| MOSI | address 0 | address 1 | address 2 | | address n | 00h |
| MISO | X | data 0 | data 1 | | data n – 1 | data n |

Remark: The Most Significant Bit (MSB) has to be sent first.

8.4.2.3 Write data

To write data to the SLRC610 using the SPI interface the following byte order has to be used. It is possible to write more than one byte by sending a single address byte (see.8.5.2.4).

The first send byte defines both, the mode itself and the address byte.

Table 10. Byte Order for MOSI and MISO

| | byte 0 | byte 1 | byte 2 | 3 to n-1 | byte n | byte n + 1 |
|------|-----------|--------|--------|----------|------------|------------|
| MOSI | address 0 | data 0 | data 1 | | data n – 1 | data n |
| MISO | X | X | X | | X | X |

Remark: The Most Significant Bit (MSB) has to be sent first.

8.4.2.4 Address byte

The address byte has to fulfil the following format:

The LSB bit of the first byte defines the used mode. To read data from the SLRC610 the LSB bit is set to logic 1. To write data to the SLRC610 the LSB bit has to be cleared. The bits 6 to 0 define the address byte.

NOTE: When writing the sequence [address byte][data1][data2][data3]..., [data1] is written to address [address byte], [data2] is written to address [address byte + 1] and [data3] is written to [address byte + 2].

Exception: This auto increment of the address byte is not performed if data is written to the FIFO address

Table 11. Address byte 0 register; address MOSI

| 7 | 6 | 5 | 4 | 3 | 2 | 1 | 0 |
|-----------|-----------|-----------|-----------|-----------|-----------|-----------|-----------------------|
| address 6 | address 5 | address 4 | address 3 | address 2 | address 1 | address 0 | 1 (read) 0 (write) |
| MSB | | | | | | | LSB |

8.4.2.5 Timing Specification SPI

The timing condition for SPI interface is as follows:

Table 12. Timing conditions SPI

| Symbol | Parameter | Min | Typ | Max | Unit |
|-------------------------|------------------------------------|-----|-----|-----|------|
| t _{SCKL} | SCK LOW time | 50 | - | - | ns |
| t _{SCKH} | SCK HIGH time | 50 | - | - | ns |
| t _{h(SCKH-D)} | SCK HIGH to data input hold time | 25 | - | - | ns |
| t _{su(D-SCKH)} | data input to SCK HIGH set-up time | 25 | - | - | ns |

Table 12. Timing conditions SPI ...continued

| Symbol | Parameter | Min | Typ | Max | Unit |
|-------------------|----------------------------------|-----|-----|-----|------|
| $t_{h(SCKL-Q)}$ | SCK LOW to data output hold time | - | - | 25 | ns |
| $t_{(SCKL-NSSH)}$ | SCK LOW to NSS HIGH time | 0 | - | - | ns |
| t_{NSSH} | NSS HIGH time | 50 | - | - | ns |

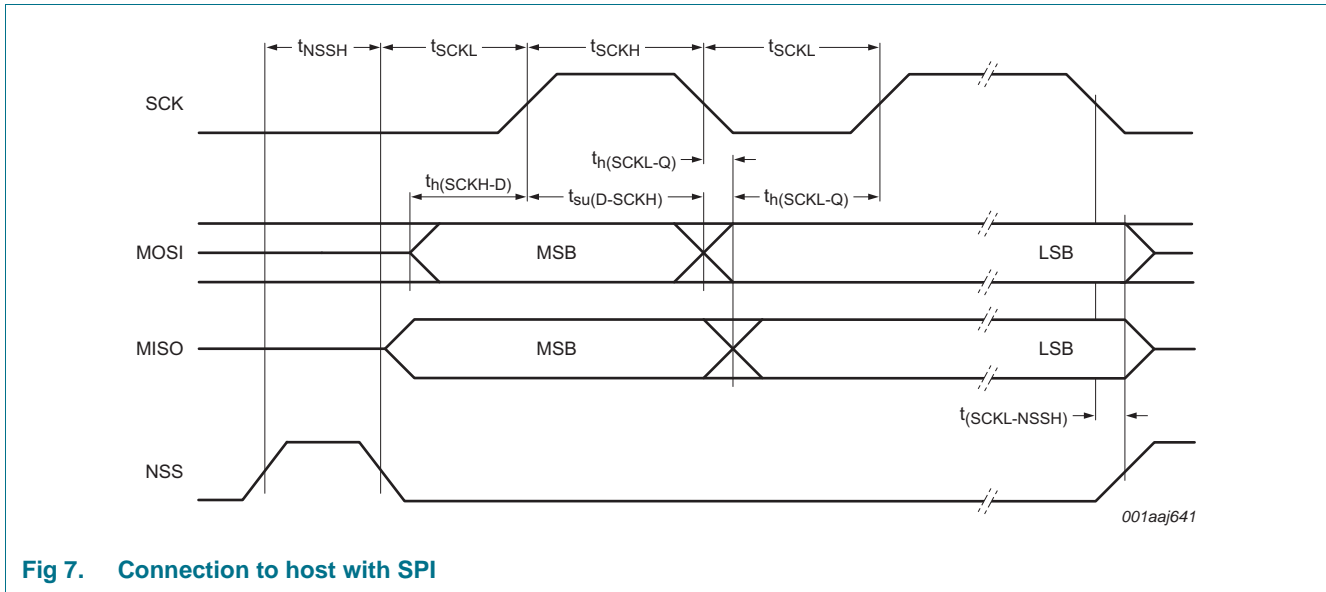

Fig 7. Connection to host with SPI

Remark: To send more bytes in one data stream the NSS signal must be LOW during the send process. To send more than one data stream the NSS signal must be HIGH between each data stream.

8.4.3 RS232 interface

8.4.3.1 Selection of the transfer speeds

The internal UART interface is compatible to a RS232 serial interface.

[Table 14 “Selectable transfer speeds”](#) describes examples for different transfer speeds and relevant register settings. The resulting transfer speed error is less than 1.5 % for all described transfer speeds. The default transfer speed is 115.2 kbit/s.

To change the transfer speed, the host controller has to write a value for the new transfer speed to the register SerialSpeedReg. The bits BR_T0 and BR_T1 define factors to set the transfer speed in the SerialSpeedReg.

[Table 13 “Settings of BR_T0 and BR_T1”](#) describes the settings of BR_T0 and BR_T1.

Table 13. Settings of BR_T0 and BR_T1

| BR_T0 | 0 | 1 | 2 | 3 | 4 | 5 | 6 | 7 |
|--------------|---------|----------|----------|----------|----------|----------|----------|----------|
| factor BR_T0 | 1 | 1 | 2 | 4 | 8 | 16 | 32 | 64 |
| range BR_T1 | 1 to 32 | 33 to 64 | 33 to 64 | 33 to 64 | 33 to 64 | 33 to 64 | 33 to 64 | 33 to 64 |

Table 14. Selectable transfer speeds

| Transfer speed (kbit/s) | Serial SpeedReg | Transfer speed accuracy (%) |
|-------------------------|-----------------|-----------------------------|
| | (Hex.) | |
| 7.2 | FA | -0.25 |
| 9.6 | EB | 0.32 |
| 14.4 | DA | -0.25 |
| 19.2 | CB | 0.32 |
| 38.4 | AB | 0.32 |
| 57.6 | 9A | -0.25 |
| 115.2 | 7A | -0.25 |
| 128 | 74 | -0.06 |
| 230.4 | 5A | -0.25 |
| 460.8 | 3A | -0.25 |
| 921.6 | 1C | 1.45 |
| 1228.8 | 15 | 0.32 |

The selectable transfer speeds as shown are calculated according to the following formulas:

if BR_T0 = 0: transfer speed = 27.12 MHz / (BR_T1 + 1)

if BR_T0 > 0: transfer speed = 27.12 MHz / (BR_T1 + 33)/2^(BR_T0 - 1)

Remark: Transfer speeds above 1228.8 kBits/s are not supported.

8.4.3.2 Framing

Table 15. UART framing

| Bit | Length | Value |
|----------------|--------|-------|
| Start bit (Sa) | 1 bit | 0 |
| Data bits | 8 bit | Data |
| Stop bit (So) | 1 bit | 1 |

Remark: For data and address bytes the LSB bit has to be sent first. No parity bit is used during transmission.

Read data: To read out data using the UART interface the flow described below has to be used. The first send byte defines both the mode itself and the address. The Trigger on pin IF3 has to be set, otherwise no read of data is possible.

Table 16. Byte Order to Read Data

| Mode | byte 0 | byte 1 |
|------|---------|--------|
| RX | address | - |
| TX | - | data 0 |

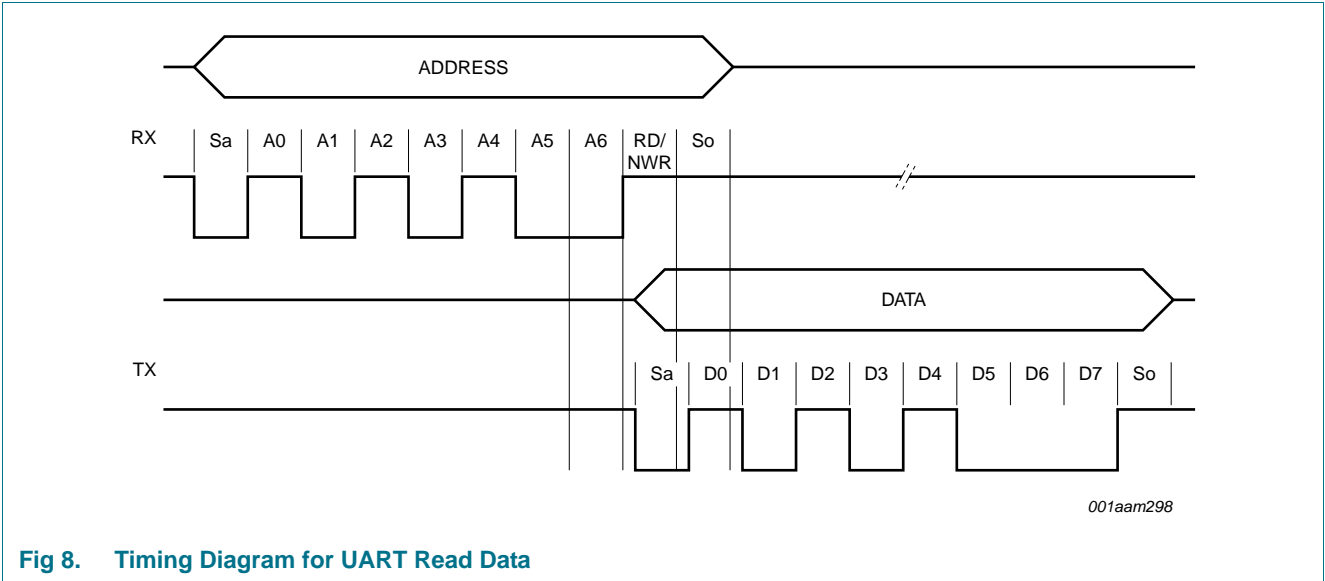

Fig 8. Timing Diagram for UART Read Data

Write data:

To write data to the SLRC610 using the UART interface the following sequence has to be used.

The first send byte defines both, the mode itself and the address.

Table 17. Byte Order to Write Data

| Mode | byte 0 | byte 1 |
|------|-----------|-----------|
| RX | address 0 | data 0 |
| TX | | address 0 |

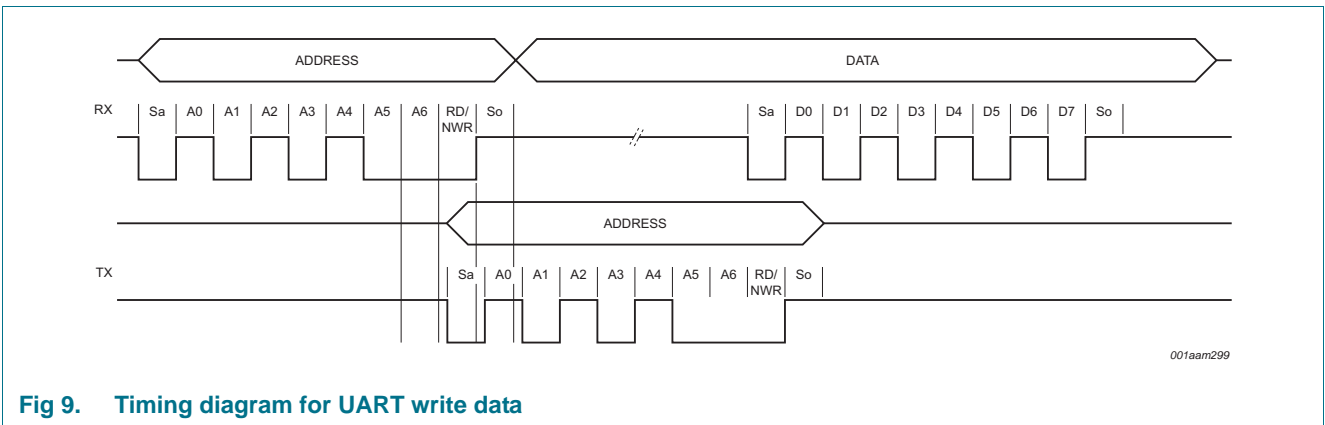

Fig 9. Timing diagram for UART write data

Remark: Data can be sent before address is received.

8.4.4 I²C-bus interface

8.4.4.1 General

An Inter IC (I²C) bus interface is supported to enable a low cost, low pin count serial bus interface to the host. The implemented I²C interface is mainly implemented according the NXP Semiconductors I²C interface specification, rev. 3.0, June 2007. The SLRC610 can act as a slave receiver or slave transmitter in standard mode, fast mode and fast mode plus.

The following features defined by the NXP Semiconductors I²C interface specification, rev. 3.0, June 2007 are not supported:

- The SLRC610 I²C interface does not stretch the clock
- The SLRC610 I²C interface does not support the general call. This means that the SLRC610 does not support a software reset
- The SLRC610 does not support the I²C device ID
- The implemented interface can only act in slave mode. Therefore no clock generation and access arbitration is implemented in the SLRC610.
- High speed mode is not supported by the SLRC610

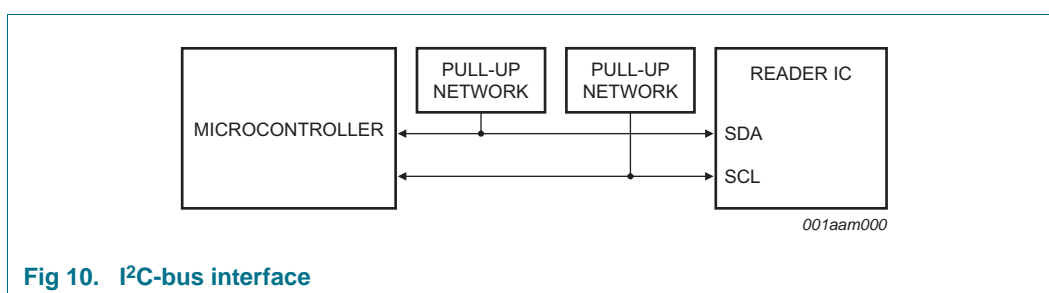

Fig 10. I²C-bus interface

SDA is a bidirectional line, connected to a positive supply voltage via a pull-up resistor. Both lines SDA and SCL are set to HIGH level if no data is transmitted. Data on the I²C-bus can be transferred at data rates of up to 400 kbit/s in fast mode, up to 1 Mbit/s in the fast mode+.

If the I²C interface is selected, a spike suppression according to the I²C interface specification on SCL and SDA is automatically activated.

For timing requirements refer to [Table 195 "I²C-bus timing in fast mode and fast mode plus"](#)

8.4.4.2 I²C Data validity

Data on the SDA line shall be stable during the HIGH period of the clock. The HIGH state or LOW state of the data line shall only change when the clock signal on SCL is LOW.

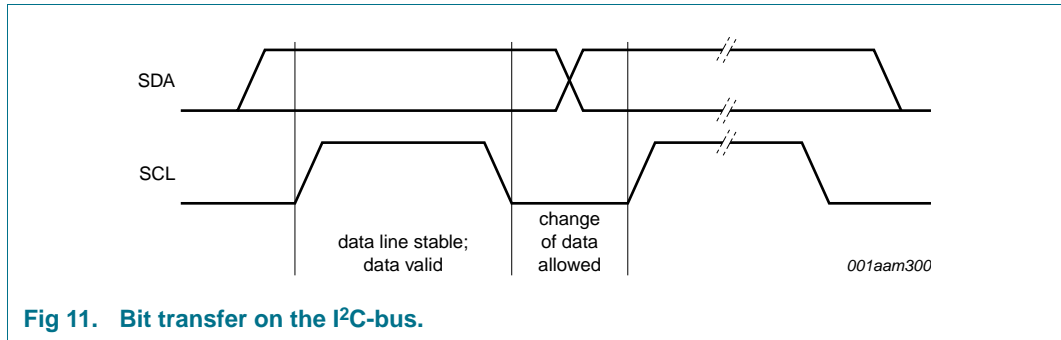

Fig 11. Bit transfer on the I²C-bus.

8.4.4.3 I²C START and STOP conditions

To handle the data transfer on the I²C-bus, unique START (S) and STOP (P) conditions are defined.

A START condition is defined with a HIGH-to-LOW transition on the SDA line while SCL is HIGH.

A STOP condition is defined with a LOW-to-HIGH transition on the SDA line while SCL is HIGH.

The master always generates the START and STOP conditions. The bus is considered to be busy after the START condition. The bus is considered to be free again a certain time after the STOP condition.

The bus stays busy if a repeated START (Sr) is generated instead of a STOP condition. In this respect, the START (S) and repeated START (Sr) conditions are functionally identical. Therefore, the S symbol will be used as a generic term to represent both the START and repeated START (Sr) conditions.

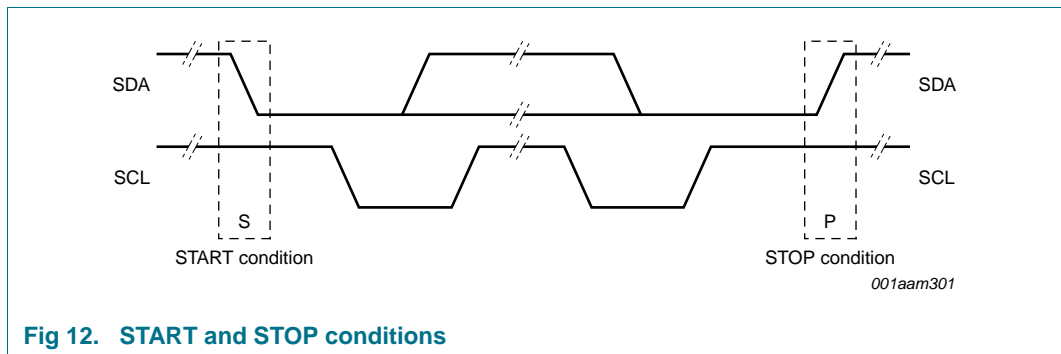

Fig 12. START and STOP conditions

8.4.4.4 I²C byte format

Each byte has to be followed by an acknowledge bit. Data is transferred with the MSB first, see Figure 12 “START and STOP conditions”. The number of transmitted bytes during one data transfer is unrestricted but shall fulfil the read/write cycle format.

8.4.4.5 I²C Acknowledge

An acknowledge at the end of one data byte is mandatory. The acknowledge-related clock pulse is generated by the master. The transmitter of data, either master or slave, releases the SDA line (HIGH) during the acknowledge clock pulse. The receiver shall pull down the SDA line during the acknowledge clock pulse so that it remains stable LOW during the HIGH period of this clock pulse.

The master can then generate either a STOP (P) condition to stop the transfer, or a repeated START (Sr) condition to start a new transfer.

A master-receiver shall indicate the end of data to the slave- transmitter by not generating an acknowledge on the last byte that was clocked out by the slave. The slave-transmitter shall release the data line to allow the master to generate a STOP (P) or repeated START (Sr) condition.

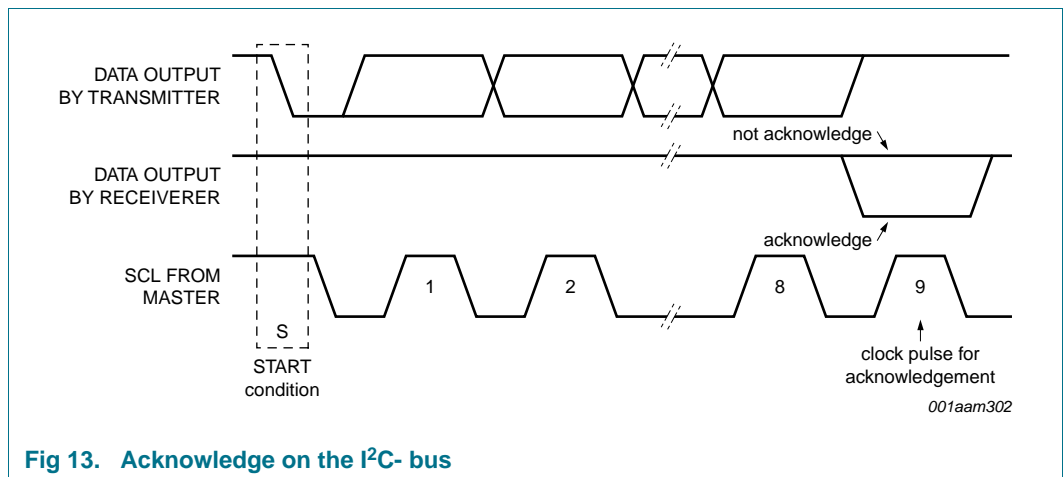

Fig 13. Acknowledge on the I²C- bus

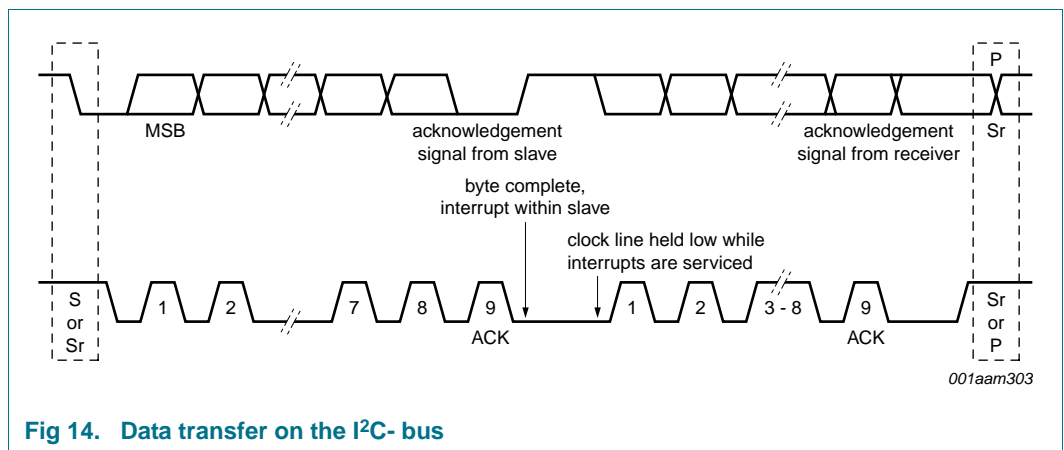

Fig 14. Data transfer on the I²C- bus

8.4.4.6 I²C 7-bit addressing

During the I²C-bus addressing procedure, the first byte after the START condition is used to determine which slave will be selected by the master.

Alternatively the I²C address can be configured in the EEPROM. Several address numbers are reserved for this purpose. During device configuration, the designer has to ensure, that no collision with these reserved addresses in the system is possible. Check the corresponding I²C specification for a complete list of reserved addresses.

For all SLRC610 devices the upper 5 bits of the device bus address are reserved by NXP and set to 01010(bin). The remaining 2 bits (ADR_2, ADR_1) of the slave address can be freely configured by the customer in order to prevent collisions with other I²C devices by using the interface pins (refer to Table 8) or the value of the I²C address EEPROM register (refer to Table 29).

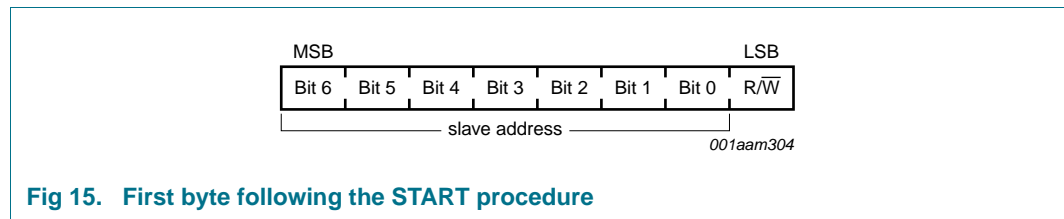

Fig 15. First byte following the START procedure

8.4.4.7 I²C-register write access

To write data from the host controller via I²C to a specific register of the SLRC610 the following frame format shall be used.

The first byte of a frame indicates the device address according to the I²C rules. The second byte indicates the register address followed by up to n-data bytes. In case the address indicates the FIFO, in one frame all n-data bytes are written to the FIFO register address. This enables for example a fast FIFO access. For any other address, the address pointer is incremented automatically and data is written to the locations [address], [address+1], [address+2]... [address+(n-1)]

The read/write bit shall be set to logic 0.

8.4.4.8 I²C-register read access

To read out data from a specific register address of the SLRC610 the host controller shall use the procedure:

First a write access to the specific register address has to be performed as indicated in the following frame:

The first byte of a frame indicates the device address according to the I²C rules. The second byte indicates the register address. No data bytes are added.

The read/write bit shall be logic 0.

Having performed this write access, the read access starts. The host sends the device address of the SLRC610. As an answer to this device address the SLRC610 responds with the content of the addressed register. In one frame n-data bytes could be read using the same register address. The address pointing to the register is incremented automatically (exception: FIFO register address is not incremented automatically). This enables a fast transfer of register content. The address pointer is incremented automatically and data is read from the locations [address], [address+1], [address+2]... [address+(n-1)]

In order to support a fast FIFO data transfer, the address pointer is not incremented automatically in case the address is pointing to the FIFO.

The read/write bit shall be set to logic 1.

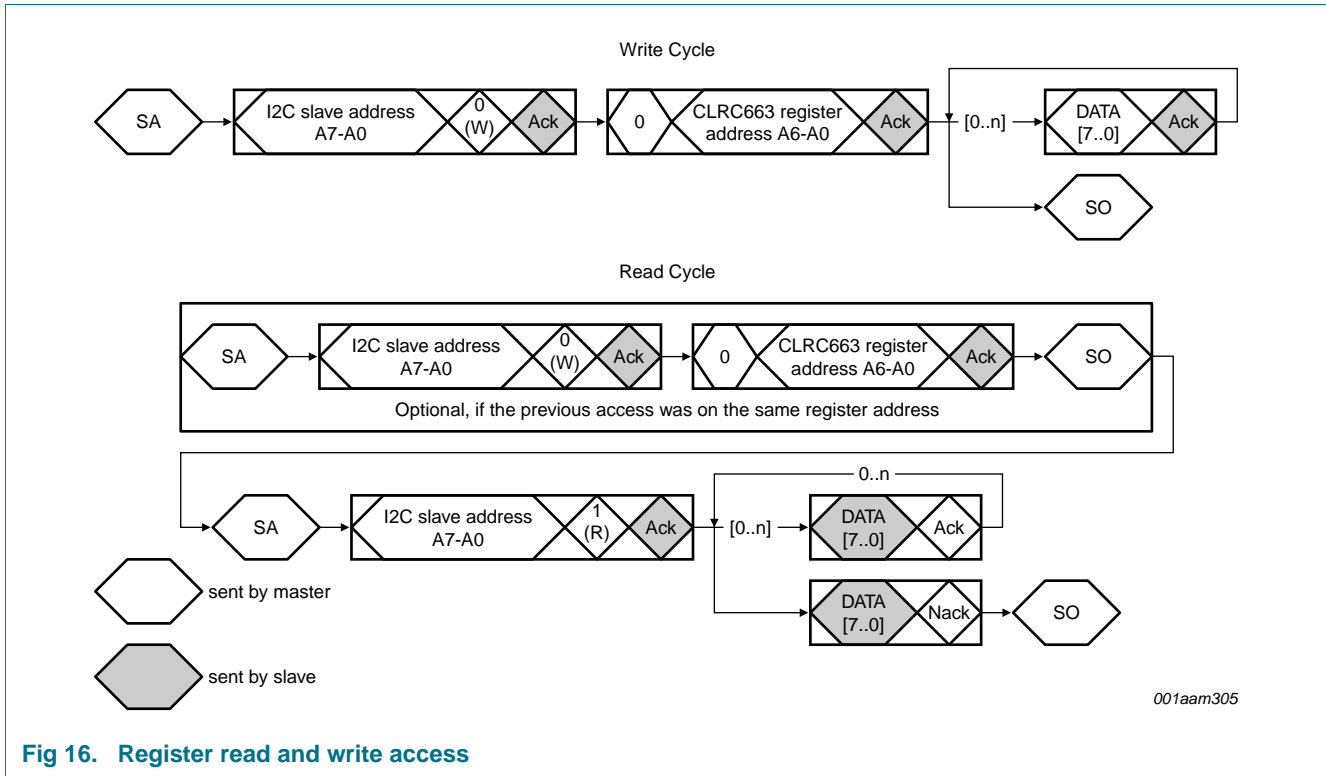

Fig 16. Register read and write access

8.4.4.9 I²CL-bus interface

The SLRC610 provides an interface option according to a logical handling of an I²C interface. This logical interface fulfills the I²C specification, but the rise/fall timings will not be according the I²C standard. Standard I/O pads are used for communication and the communication speed is limited to 5 MBaud. The protocol itself is equivalent to the fast mode protocol of I²C. The address is 01010xxb, where the last two bits of the address can be defined by the application. The definition of this bits can be done by two options. With a pin, where the higher bit is fixed to 0 or the configuration can be defined via EEPROM. Refer to the EEPROM configuration in [Section 8.7](#).

Table 18. Timing parameter I²CL

| Parameter | Min | Max | Unit |
|---------------------|-----|-----|------|
| f _{SCL} | 0 | 5 | MHz |
| t _{HD;STA} | 80 | - | ns |
| t _{LOW} | 100 | - | ns |
| t _{HIGH} | 100 | - | ns |
| t _{SU;SDA} | 80 | - | ns |
| t _{HD;DAT} | 0 | 50 | ns |
| t _{SU;DAT} | 0 | 20 | ns |
| t _{SU;STO} | 80 | - | ns |
| t _{BUF} | 200 | - | ns |

The pull-up resistor is not required for the I²CL interface. Instead, a on chip buskeeper is implemented in the SLRC610 for SDA of the I²CL interface. This protocol is intended to be used for a point to point connection of devices over a short distance and does not support a bus capability. The driver of the pin must force the line to the desired logic voltage. To avoid that two drivers are pushing the line at the same time following regulations must be fulfilled:

SCL: As there is no clock stretching, the SCL is always under control of the Master.

SDA: The SDA line is shared between master and slave. Therefore the master and the slave must have the control over the own driver enable line of the SDA pin. The following rules must be followed:

- In the idle phase the SDA line is driven high by the master
- In the time between start and stop condition the SDA line is driven by master or slave when SCL is low. If SCL is high the SDA line is not driven by any device
- To keep the value on the SDA line a on chip buskeeper structure is implemented for the line

8.4.5 SAM interface I²C

8.4.5.1 SAM functionality

The SLRC610 implements a dedicated I2C interface to integrate a MIFARE SAM (Secure Access Module) in a very convenient way into applications (e.g. a proximity reader). The SAM can be connected to the microcontroller to operate like a cryptographic co-processor. For any cryptographic task, the microcontroller requests a operation from the SAM, receives the answer and sends it over a host interface (e.g. I2C, SPI) interface to the connected reader IC.

The MIFARE SAM supports a optimized method to integrate the SAM in a very efficient way to reduce the protocol overhead. In this system configuration, the SAM is integrated between the microprocessor and the reader IC, connected by one interface to the reader IC and by another interface to the microcontroller. In this application the microcontroller accesses the SAM using the T=1 protocol and the SAM accesses the reader IC using an I2C interface. As the SAM is directly communicating with reader IC, the communication overhead is reduced. In this configuration, a performance boost of up to 40% can be achieved for a transaction time.

The MIFARE SAM supports applications using MIFARE cards. For multi application purposes an architecture connecting the microcontroller additionally directly to the reader IC is recommended. This is possible by connecting the SLRC610 on one interface (SAM Interface SDA, SCL) with the MIFARE SAM AV2.6 (P5DF081XX/T1AR1070) and by connecting the microcontroller to the S2C or SPI interface.

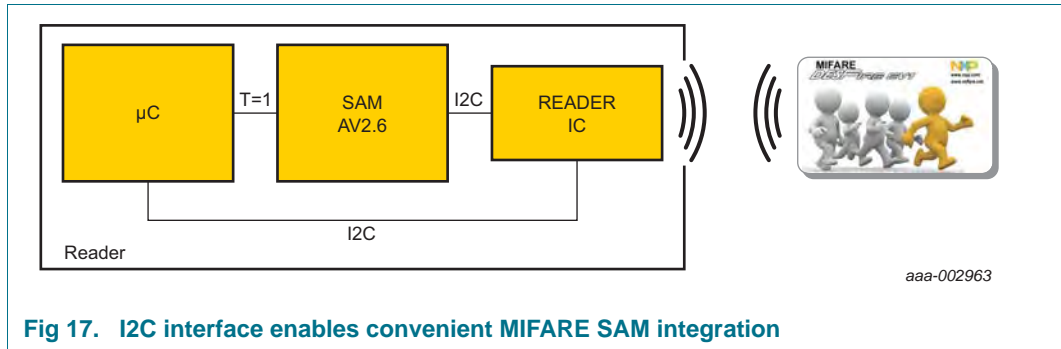

Fig 17. I2C interface enables convenient MIFARE SAM integration

8.4.5.2 SAM connection

The SLRC610 provides an interface to connect a SAM dedicated to the SLRC610. Both interface options of the SLRC610, I²C or I²CL can be used for this purpose. The interface option of the SAM itself is configured by a host command sent from the host to the SAM.

The I²CL interface is intended to be used as connection between two IC's over a short distance. The protocol fulfills the I²C specification, but does support a single device connected to the bus only.

8.4.6 Boundary scan interface

The SLRC610 provides a boundary scan interface according to the IEEE 1149.1. This interface allows to test interconnections without using physical test probes. This is done by test cells, assigned to each pin, which override the functionality of this pin.

To be able to program the test cells, the following commands are supported:

Table 19. Boundary scan command

| Value (decimal) | Command | Parameter in | Parameter out |
|-----------------|-----------------------|------------------------|---------------|
| 0 | bypass | - | - |
| 1 | preload | data (24) | - |
| 1 | sample | - | data (24) |
| 2 | ID code (default) | - | data (32) |
| 3 | USER code | - | data (32) |
| 4 | Clamp | - | - |
| 5 | HIGH Z | - | - |
| 7 | extest | data (24) | data (24) |
| 8 | interface on/off | interface (1) | - |
| 9 | register access read | address (7) | data (8) |
| 10 | register access write | address (7) - data (8) | - |

The Standard IEEE 1149.1 describes the four basic blocks necessary to use this interface: Test Access Port (TAP), TAP controller, TAP instruction register, TAP data register;

8.4.6.1 Interface signals

The boundary scan interface implements a four line interface between the chip and the environment. There are three Inputs: Test Clock (TCK); Test Mode Select (TMS); Test Data Input (TDI) and one output Test Data Output (TDO). TCK and TMS are broadcast signals, TDI to TDO generate a serial line called Scan path.

Advantage of this technique is that independent of the numbers of boundary scan devices the complete path can be handled with four signal lines.

The signals TCK, TMS are directly connected with the boundary scan controller. Because these signals are responsible for the mode of the chip, all boundary scan devices in one scan path will be in the same boundary scan mode.

8.4.6.2 Test Clock (TCK)

The TCK pin is the input clock for the module. If this clock is provided, the test logic is able to operate independent of any other system clocks. In addition, it ensures that multiple boundary scan controllers that are daisy-chained together can synchronously communicate serial test data between components. During normal operation, TCK is driven by a free-running clock. When necessary, TCK can be stopped at 0 or 1 for extended periods of time. While TCK is stopped at 0 or 1, the state of the boundary scan controller does not change and data in the Instruction and Data Registers is not lost.

The internal pull-up resistor on the TCK pin is enabled. This assures that no clocking occurs if the pin is not driven from an external source.

8.4.6.3 Test Mode Select (TMS)

The TMS pin selects the next state of the boundary scan controller. TMS is sampled on the rising edge of TCK. Depending on the current boundary scan state and the sampled value of TMS, the next state is entered. Because the TMS pin is sampled on the rising edge of TCK, the IEEE Standard 1149.1 expects the value on TMS to change on the falling edge of TCK.

Holding TMS high for five consecutive TCK cycles drives the boundary scan controller state machine to the Test-Logic-Reset state. When the boundary scan controller enters the Test-Logic-Reset state, the Instruction Register (IR) resets to the default instruction, IDCODE. Therefore, this sequence can be used as a reset mechanism.

The internal pull-up resistor on the TMS pin is enabled.

8.4.6.4 Test Data Input (TDI)

The TDI pin provides a stream of serial information to the IR chain and the DR chains. TDI is sampled on the rising edge of TCK and, depending on the current TAP state and the current instruction, presents this data to the proper shift register chain. Because the TDI pin is sampled on the rising edge of TCK, the IEEE Standard 1149.1 expects the value on TDI to change on the falling edge of TCK.

The internal pull-up resistor on the TDI pin is enabled.

8.4.6.5 Test Data Output (TDO)

The TDO pin provides an output stream of serial information from the IR chain or the DR chains. The value of TDO depends on the current TAP state, the current instruction, and the data in the chain being accessed. In order to save power when the port is not being

used, the TDO pin is placed in an inactive drive state when not actively shifting out data. Because TDO can be connected to the TDI of another controller in a daisy-chain configuration, the IEEE Standard 1149.1 expects the value on TDO to change on the falling edge of TCK.

8.4.6.6 Data register

According to the IEEE1149.1 standard there are two types of data register defined: bypass and boundary scan

The bypass register enable the possibility to bypass a device when part of the scan path. Serial data is allowed to be transferred through a device from the TDI pin to the TDO pin without affecting the operation of the device.

The boundary scan register is the scan-chain of the boundary cells. The size of this register is dependent on the command.

8.4.6.7 Boundary scan cell

The boundary scan cell opens the possibility to control a hardware pin independent of its normal use case. Basically the cell can only do one of the following: control, output and input.

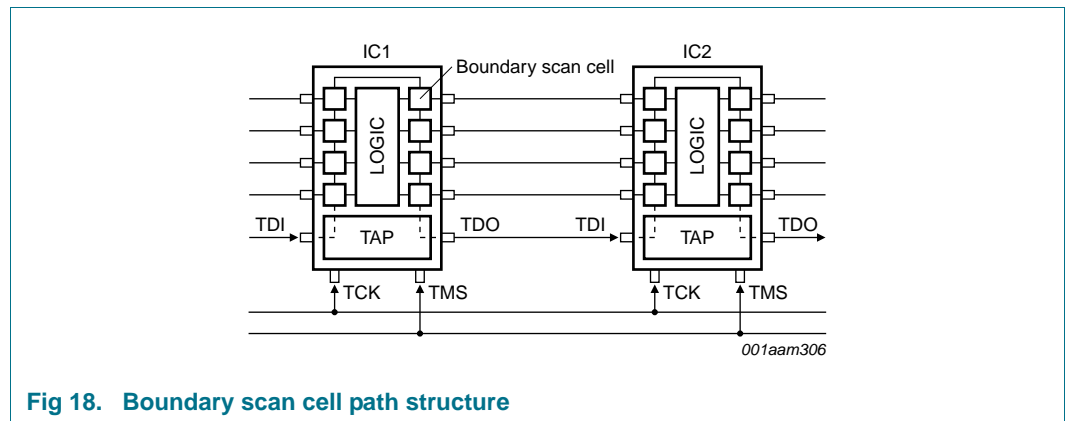

Fig 18. Boundary scan cell path structure

8.4.6.8 Boundary scan path

This chapter shows the boundary scan path of the SLRC610.

Table 20. Boundary scan path of the SLRC610

| Number (decimal) | Cell | Port | Function |
|------------------|------|--------|----------|
| 23 | BC_1 | - | Control |
| 22 | BC_8 | CLKOUT | Bidir |
| 21 | BC_1 | - | Control |
| 20 | BC_8 | SCL2 | Bidir |
| 19 | BC_1 | - | Control |
| 18 | BC_8 | SDA2 | Bidir |
| 17 | BC_1 | - | Control |
| 16 | BC_8 | IFSEL0 | Bidir |
| 15 | BC_1 | - | Control |
| 14 | BC_8 | IFSEL1 | Bidir |

Table 20. Boundary scan path of the SLRC610

| Number (decimal) | Cell | Port | Function |
|------------------|------|--------|----------|
| 13 | BC_1 | - | Control |
| 12 | BC_8 | IF0 | Bidir |
| 11 | BC_1 | - | Control |
| 10 | BC_8 | IF1 | Bidir |
| 9 | BC_1 | - | Control |
| 8 | BC_8 | IF2 | Bidir |
| 7 | BC_1 | IF2 | Output2 |
| 6 | BC_4 | IF3 | Bidir |
| 5 | BC_1 | - | Control |
| 4 | BC_8 | IRQ | Bidir |
| 3 | BC_1 | - | Control |
| 2 | BC_8 | SIGIN | Bidir |
| 1 | BC_1 | - | Control |
| 0 | BC_8 | SIGOUT | Bidir |

Refer to the SLRC610 BSDL file.

8.4.6.9 Boundary Scan Description Language (BSDL)

All of the boundary scan devices have a unique boundary structure which is necessary to know for operating the device. Important components of this language are:

- available test bus signal
- compliance pins
- command register
- data register
- boundary scan structure (number and types of the cells, their function and the connection to the pins.)

The SLRC610 is using the cell BC_8 for the IO-Lines. The I²C Pin is using a BC_4 cell. For all pad enable lines the cell BC1 is used.

The manufacturer's identification is 02Bh.

- attribute IDCODEISTER of SLRC610: entity is "0001" and -- version
- "0011110010000010b" and -- part number (3C82h)
- "00000010101b" and -- manufacturer (02Bh)
- "1b"; -- mandatory

The user code data is coded as followed:

- product ID (3 bytes)
- version

These four bytes are stored as the first four bytes in the EEPROM.

8.4.6.10 Non-IEEE1149.1 commands

Interface on/off: With this command the host/SAM interface can be deactivated and the Read and Write command of the boundary scan interface is activated. (Data = 1). With Update-DR the value is taken over.

Register Access Read: At Capture-DR the actual address is read and stored in the DR. Shifting the DR is shifting in a new address. With Update-DR this address is taken over into the actual address.

8.5 Buffer

8.5.1 Overview

An 512 × 8-bit FIFO buffer is implemented in the SLRC610. It buffers the input and output data stream between the host and the internal state machine of the SLRC610. Thus, it is possible to handle data streams with lengths of up to 512 bytes without taking timing constraints into account. The FIFO can also be limited to a size of 255 byte. In this case all the parameters (FIFO length, Watermark...) require a single byte only for definition. In case of a 512 byte FIFO length the definition of this values requires 2 bytes.

8.5.2 Accessing the FIFO buffer

When the μ -Controller starts a command, the SLRC610 may, while the command is in progress, access the FIFO-buffer according to that command. Physically only one FIFO-buffer is implemented, which can be used in input and output direction. Therefore the μ -Controller has to take care, not to access the FIFO buffer in a way that corrupts the FIFO data.

8.5.3 Controlling the FIFO buffer

Besides writing to and reading from the FIFO buffer, the FIFO-buffer pointers might be reset by setting the bit FIFOFlush in FIFOControl to 1. Consequently, the FIFOLevel bits are set to logic 0, the actually stored bytes are not accessible any more and the FIFO buffer can be filled with another 512 bytes (or 255 bytes if the bit FIFOSize is set to 1) again.

8.5.4 Status Information about the FIFO buffer

The host may obtain the following data about the FIFO-buffers status:

- Number of bytes already stored in the FIFO-buffer. Writing increments, reading decrements the FIFO level: FIFOLength in register FIFOLength (and FIFOControl Register in 512 byte mode)
- Warning, that the FIFO-buffer is almost full: HiAlert in register FIFOControl according to the value of the water level in register WaterLevel (Register 02h bit [2], Register 03h bit[7:0])
- Warning, that the FIFO-buffer is almost empty: LoAlert in register FIFOControl according to the value of the water level in register WaterLevel (Register 02h bit [2], Register 03h bit[7:0])
- FIFOOvl bit indicates, that bytes were written to the FIFO buffer although it was already full: ErrIrq in register Irq0.

WaterLevel is one single value defining both HiAlert (counting from the FIFO top) and LoAlert (counting from the FIFO bottom). The SLRC610 can generate an interrupt signal if:

- LoAlertIRQEn in register IRQ0En is set to logic 1 it will activate pin IRQ when LoAlert in the register FIFOControl changes to 1.
- HiAlertIRQEN in register IRQ0En is set to logic 1 it will activate pin IRQ when HiAlert in the register FIFOControl changes to 1.

The bit HiAlert is set to logic 1 if maximum water level bytes (as set in register WaterLevel) or less can be stored in the FIFO-buffer. It is generated according to the following equation:

$$HiAlert = (FiFoSize - FiFoLength) \leq WaterLevel \quad (2)$$

The bit LoAlert is set to logic 1 if water level bytes (as set in register WaterLevel) or less are actually stored in the FIFO-buffer. It is generated according to the following equation:

$$LoAlert = FiFoLength \leq WaterLevel \quad (3)$$

8.6 Analog interface and contactless UART

8.6.1 General

The integrated contactless UART supports the external host online with framing and error checking of the protocol requirements up to 848 kbit/s. An external circuit can be connected to the communication interface pins SIGIN and SIGOUT to modulate and demodulate the data.

The contactless UART handles the protocol requirements for the communication schemes in co-operation with the host. The protocol handling itself generates bit- and byte-oriented framing and handles error detection like Parity and CRC according to the different contactless communication schemes.

The size, the tuning of the antenna, and the supply voltage of the output drivers have an impact on the achievable field strength. The operating distance between reader and card depends additionally on the type of card used.

8.6.2 TX transmitter

The signal delivered on pin TX1 and pin TX2 is the 13.56 MHz carrier modulated by an envelope signal for energy and data transmission. It can be used to drive an antenna directly, using a few passive components for matching and filtering, see [Section 14 "Application information"](#). The signal on TX1 and TX2 can be configured by the register DrvMode, see [Section 9.8.1 "TxMode"](#).

The modulation index can be set by the TxAmp.

Following figure shows the general relations during modulation

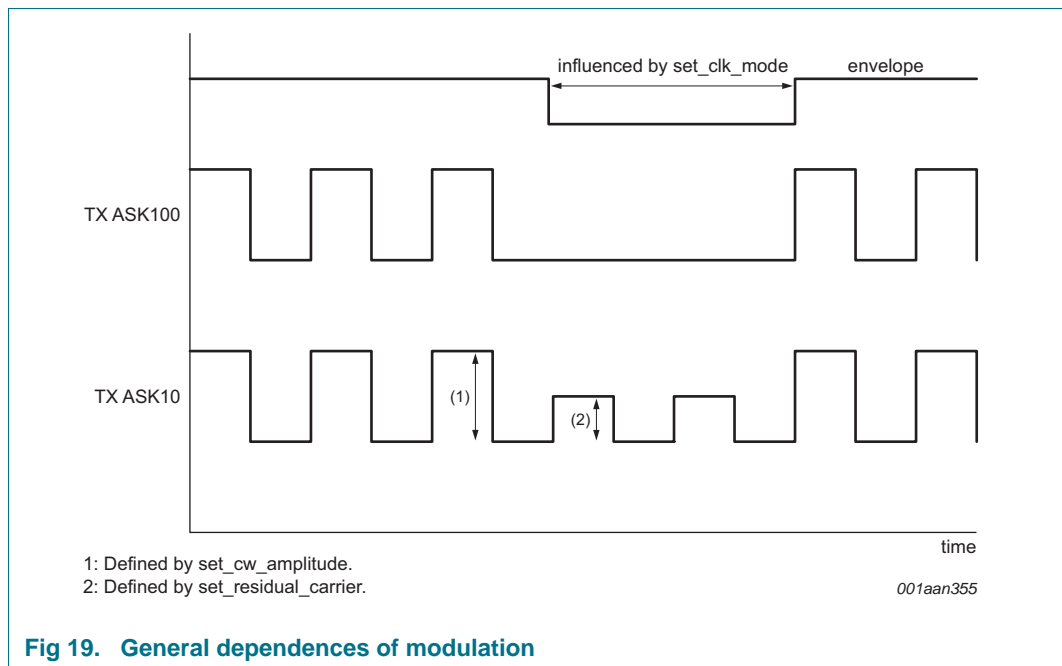

Fig 19. General dependences of modulation

Note: When changing the continuous carrier amplitude, the residual carrier amplitude also changes, while the modulation index remains the same.

The registers [Section 9.8](#) and [Section 9.10](#) control the data rate, the framing during transmission and the setting of the antenna driver to support the requirements at the different specified modes and transfer speeds.

Table 21. Settings for TX1 and TX2

| TxClockMode (binary) | Tx1 and TX2 output | Remarks |
|----------------------|--|---|
| 000 | High impedance | - |
| 001 | 0 | output pulled to 0 in any case |
| 010 | 1 | output pulled to 1 in any case |
| 110 | RF high side push | open drain, only high side (push) MOS supplied with clock, clock parity defined by invtx; low side MOS is off |
| 101 | RF low side pull | open drain, only low side (pull) MOS supplied with clock, clock parity defined by invtx; high side MOS is off |
| 111 | 13.56 MHz clock derived from 27.12 MHz quartz divided by 2 | push/pull Operation, clock polarity defined by invtx; setting for 10% modulation |

Register TXamp and the bits for set_residual_carrier define the modulation index:

Table 22. Setting residual carrier and modulation index by TXamp.set_residual_carrier

| set_residual_carrier (decimal) | residual carrier [%] | modulation index [%] |
|--------------------------------|----------------------|----------------------|
| 0 | 99 | 0.5 |
| 1 | 98 | 1.0 |
| 2 | 96 | 2.0 |
| 3 | 94 | 3.1 |
| 4 | 91 | 4.7 |
| 5 | 89 | 5.8 |
| 6 | 87 | 7.0 |
| 7 | 86 | 7.5 |
| 8 | 85 | 8.1 |
| 9 | 84 | 8.7 |
| 10 | 83 | 9.3 |
| 11 | 82 | 9.9 |
| 12 | 81 | 10.5 |
| 13 | 80 | 11.1 |
| 14 | 79 | 11.7 |
| 15 | 78 | 12.4 |
| 16 | 77 | 13.0 |
| 17 | 76 | 13.6 |
| 18 | 75 | 14.3 |
| 19 | 74 | 14.9 |
| 20 | 72 | 16.3 |
| 21 | 70 | 17.6 |
| 22 | 68 | 19.0 |

Table 22. Setting residual carrier ...continued and modulation index by

| set_residual_carrier (decimal) | residual carrier [%] | modulation index [%] |
|--------------------------------|----------------------|----------------------|
| 23 | 65 | 21.2 |
| 24 | 60 | 25.0 |
| 25 | 55 | 29.0 |
| 26 | 50 | 33.3 |
| 27 | 45 | 37.9 |
| 28 | 40 | 42.9 |
| 29 | 35 | 48.1 |
| 30 | 30 | 53.8 |
| 31 | 25 | 60.0 |

Note: At VDD(TVDD) <5 V and residual carrier settings <50%, the accuracy of the modulation index may be low in dependency of the antenna tuning impedance

8.6.2.1 Overshoot protection

The SLRC610 provides an overshoot protection for 100% ASK to avoid overshoots during a PCD communication. Therefore two timers overshoot_t1 and overshoot_t2 can be used.

During the timer overshoot_t1 runs an amplitude defined by set_cw_amplitude bits is provided to the output driver. Followed by an amplitude denoted by set_residual_carrier bits with the duration of overshoot_t2.

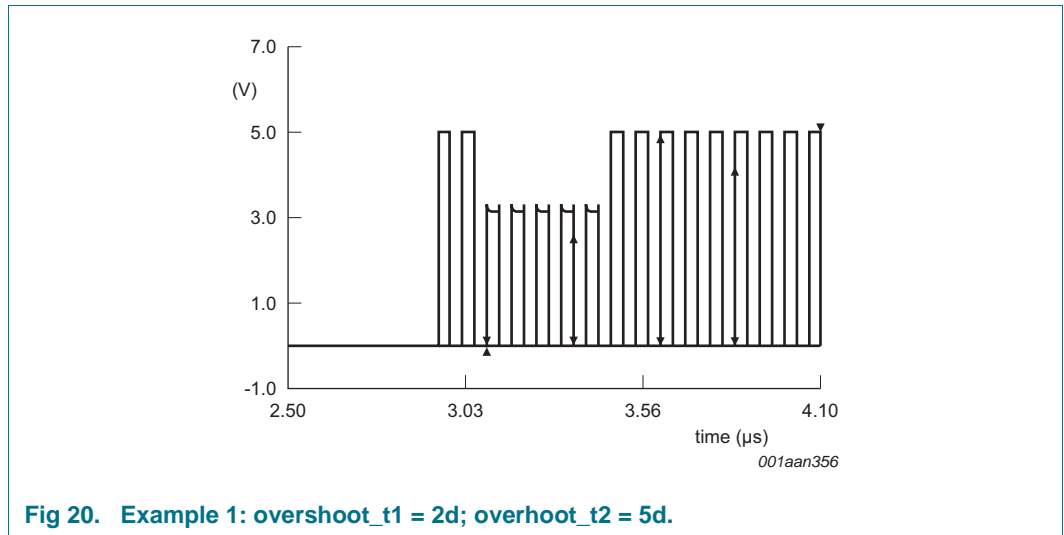

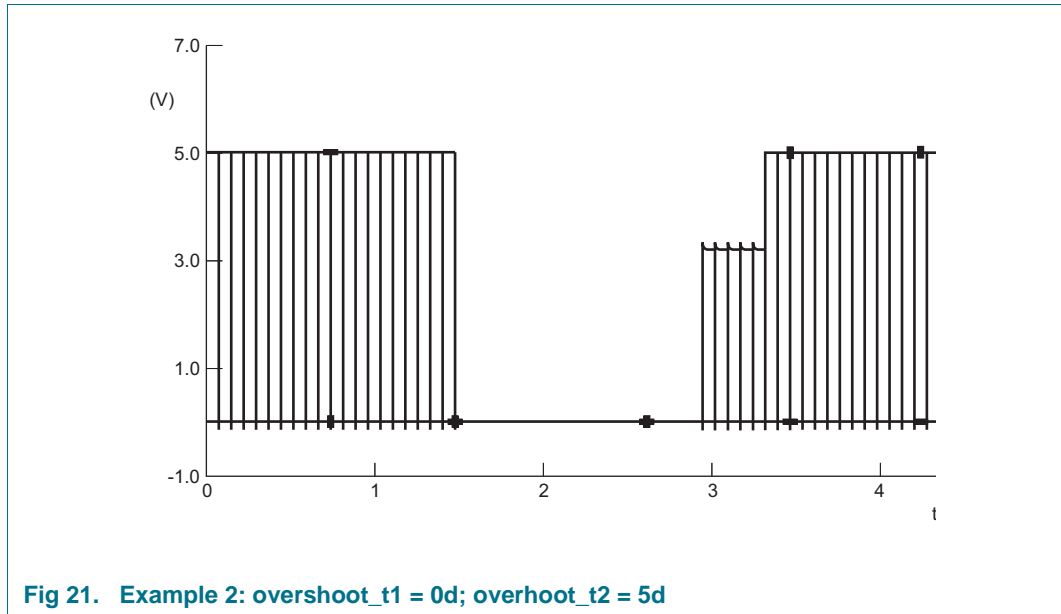

Fig 21. Example 2: overshoot_t1 = 0d; overhoot_t2 = 5d

8.6.2.2 Bit generator

The default coding of a data stream is done by using the Bit-Generator. It is activated when the value of TxFrameCon.DCodeType is set to 0000 (bin). The Bit-Generator encodes the data stream byte-wise and can apply the following encoding steps to each data byte.

1. Add a start-bit of specified type at beginning of every byte
2. Add a stop-bit and EGT bits of a specified type. The maximum number of EGT bit is 6, only full bits are supported
3. Add a parity-bit of a specified type
4. TxFirstBits (skips a given number of bits at the beginning of the first byte in a frame)
5. TxLastBits (skips a given number of bits at the end of the last byte in a frame)
6. Encrypt data-bit (MIFARE encryption)

TxFirstBits and TxLastBits can be used at the same time. If only a single data byte is sent, it must be ensured that the range of TxFirstBits and TxLastBits do not overlap. It is not possible to skip more than 8 bit of a single byte! $(8 - TxFirstBits) + (8 - TxLastBits) < 8$

By default, data bytes are always treated LSB first. To make use of a MSB first coding, the TxMSBFirst in the register CLCON1 needs to be set.

8.6.3 Receiver circuitry

8.6.3.1 General

The SLRC610 features a versatile quadrature receiver architecture with fully differential signal input at RXP and RXN. It can be configured to achieve optimum performance for reception of various 13.56 MHz based protocols.

For all processing units various adjustments can be made to obtain optimum performance.

8.6.3.2 Block diagram

Figure 22 shows the block diagram of the receiver circuitry. The receiving process includes several steps. First the quadrature demodulation of the carrier signal of 13.56 MHz is done. Several tuning steps in this circuit are possible.

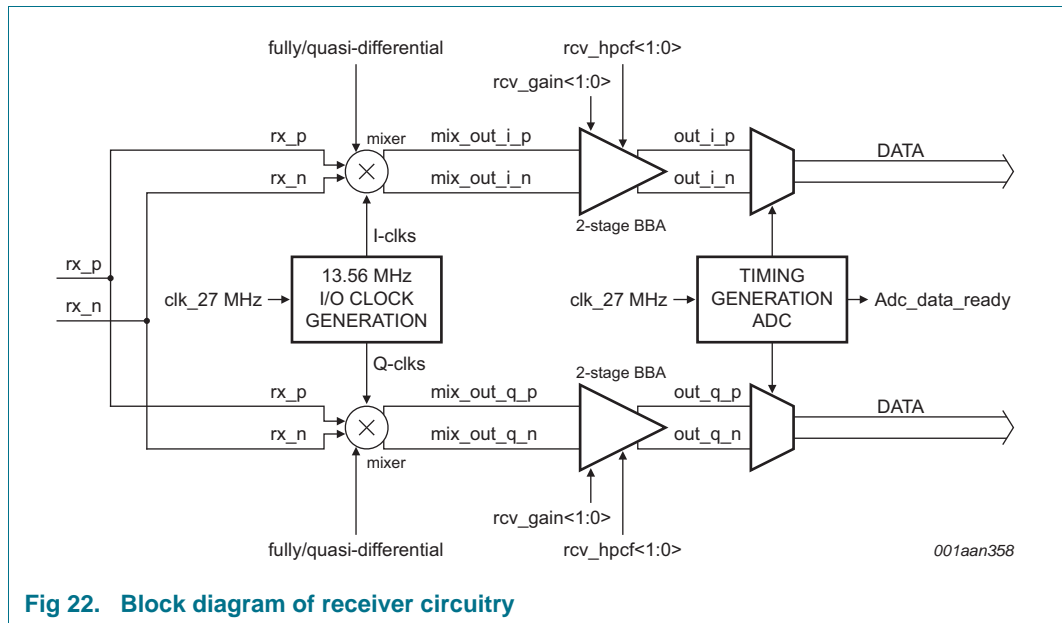

Fig 22. Block diagram of receiver circuitry

The receiver can also be operated in a single ended mode. In this case the Rcv_RX_single bit has to be set. In the single ended mode, the two receiver pins RXP and RXN need to be connected together and will provide a single ended signal to the receiver circuitry.

When using the receiver in a single ended mode the receiver sensitivity is decreased and the achievable reading distance might be reduced, compared to the fully differential mode.

Table 23. Configuration for single or differential receiver

| Mode | rcv_rx_single | pins RXP and RXN |
|--------------------|---------------|--|
| Fully differential | 0 | provide differential signal from differential antenna by separate rx-coupling branches |
| Quasi differential | 1 | connect RXP and RXN together and provide single ended signal from antenna by a single rx-coupling branch |

The quadrature-demodulator uses two different clocks, Q-clock and I-clock, with a phase shift of 90° between them. Both resulting baseband signals are amplified, filtered, digitized and forwarded to a correlation circuitry.

The typical application is intended to implement the Fully differential mode and will deliver maximum reader/writer distance. The Quasi differential mode can be used together with dedicated antenna topologies that allow a reduction of matching components at the cost of overall reading performance.

During low power card detection the DC levels at the I- and Q-channel mixer outputs are evaluated. This requires that mixers are directly connected to the ADC. This can be configured by setting the bit Rx_ADCmode in register Rcv (38h).

8.6.4 Active antenna concept

Two main blocks are implemented in the SLRC610. A digital circuitry, comprising state machines, coder and decoder logic and an analog circuitry with the modulator and antenna drivers, receiver and amplification circuitry. For example, the interface between these two blocks can be configured in the way, that the interfacing signals may be routed to the pins SIGIN and SIGOUT. The most important use of this topology is the active antenna concept where the digital and the analog blocks are separated. This opens the possibility to connect e.g. an additional digital block of another SLRC610 device with a single analog antenna front-end.

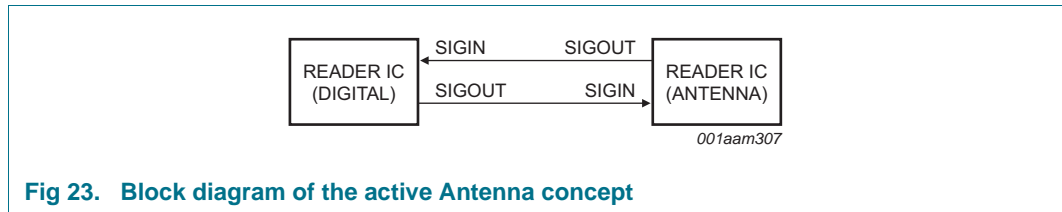

Fig 23. Block diagram of the active Antenna concept

The [Table 24](#) and [Table 25](#) describe the necessary register configuration for the use case active antenna concept.

Table 24. Register configuration of SLRC610 active antenna concept (DIGITAL)

| Register | Value (binary) | Description |
|------------------|----------------|-----------------------------------|
| SigOut.SigOutSel | 0100 | TxEnvelope |
| Rcv.SigInSel | 11 | Receive over SigIn (Generic Code) |
| DrvCon.TxSel | 00 | Low (idle) |

Table 25. Register configuration of SLRC610 active antenna concept (Antenna)

| Register | Value (binary) | Description |
|-------------------|----------------|---------------------------|
| SigOut.SigOutSel | 0110 | Generic Code (Manchester) |
| Rcv.SigInSel | 01 | Internal |
| DrvCon.TxSel | 10 | External (SigIn) |
| RxCtrl.RxMultiple | 1 | RxMultiple on |

The interface between these two blocks can be configured in the way, that the interfacing signals may be routed to the pins SIGIN and SIGOUT (see [Figure 24 “Overview SIGIN/SIGOUT Signal Routing”](#)).

This topology supports, that some parts of the analog part of the SLRC610 may be connected to the digital part of another device.

The switch SigOutSel in registerSigOut can be used to measure signals. This is especially important during the design In phase or for test purposes to check the transmitted and received data.

However, the most important use of SIGIN/SIGOUT pins is the active antenna concept. An external active antenna circuit can be connected to the digital circuit of the SLRC610. SigOutSel has to be configured in that way that the signal of the internal Miller Coder is sent to SIGOUT pin (SigOutSel = 4). SigInSel has to be configured to receive Manchester signal with sub-carrier from SIGIN pin (SigInSel = 1).

It is possible, to connect a passive antenna to pins TX1, TX2 and RX (via the appropriate filter and matching circuit) and at the same time an active antenna to the pins SIGOUT and SIGIN. In this configuration, two RF-parts may be driven (one after another) by a single host processor.

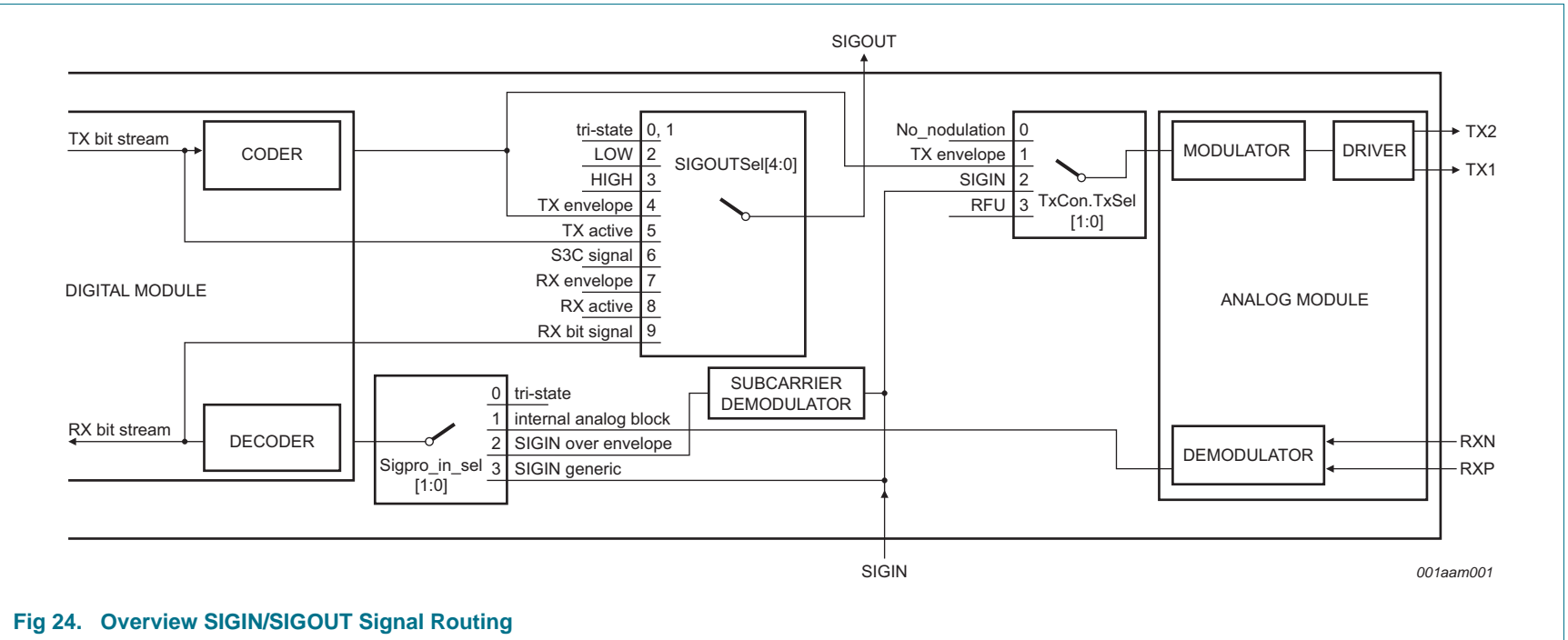

Fig 24. Overview SIGIN/SIGOUT Signal Routing

8.6.5 Symbol generator

The symbol generator is used to create various protocol symbols like the CS symbol as used by the ICODE EPC protocol.

Symbols are defined by means of the symbol definition registers and the mode registers. Four different symbols can be used. Two of them, Symbol0 and Symbol1 have a maximum pattern length of 16 bit and feature a burst length of up to 256 bits of either logic "0" or logic "1". The Symbol2 and Symbol3 are limited to 8 bit pattern length and do not support a burst.

The definition of symbol patterns is done by writing the bit sequence of the pattern to the appropriate register. The last bit of the pattern to be sent is located at the LSB of the register. By setting the symbol length in the symbol-length register (TxSym10Len and TxSym32Len) the definition of the symbol pattern is completed. All other bits at bit-position higher than the symbol length in the definition register are ignored. (Example: length of Symbol2 = 5, bit7 and bit6 are ignored, bit5 to bit0 define the symbol pattern, bit5 is sent first)

Which symbol-pattern is sent can be configured in the TxFrameCon register. Symbol0, Symbol1 and Symbol2 can be sent before data packets, Symbol1, Symbol2 and Symbol3 can be sent after data packets. Each symbol is defined by a set of registers. Symbols are configured by a pair of registers. Symbol0 and Symbol1 share the same configuration and Symbol2 and Symbol3 share the same configuration. The configuration includes setting of bit-clock- and subcarrier-frequency, as well as selection of the pulse type/length and the envelope type.

8.7 Memory

8.7.1 Memory overview

The SLRC610 implements three different memories: EEPROM, FIFO and Registers.

At startup, the initialization of the registers which define the behavior of the IC is performed by an automatic copy of an EEPROM area (read/write EEPROM section1 and section2, register reset) into the registers. The behavior of the SLRC610 can be changed by executing the command LoadProtocol, which copies a selected default protocol from the EEPROM (read only EEPROM section4, register Set Protocol area) into the registers.

The read/write EEPROM section2 can be used to store any user data or predefined register settings. These predefined settings can be copied with the command "LoadRegister" into the internal registers.

The FIFO is used as Input/Out buffer and is able to improve the performance of a system with limited interface speed.

8.7.2 EEPROM memory organization

The SLRC610 has implemented a EEPROM non-volatile memory with a size of 8 kB. The EEPROM is organized in pages of 64 bytes. One page of 64 bytes can be programmed at a time. Defined purposes had been assigned to specific memory areas of the EEPROM, which are called Sections. Five sections 0..4 with different purpose do exist.

Table 26. EEPROM memory organization

| Section | Page | Byte addresses | Access rights | Memory content |
|---------|------------|----------------|---------------|---------------------------------------|
| 0 | 0 | 00 to 31 | r | product information and configuration |
| | | 32 to 63 | r/w | product configuration |
| 1 | 1 to 2 | 64 to 191 | r/w | register reset |
| 2 | 3 to 111 | 192 to 7167 | r/w | free |
| 3 | 112 to 128 | 7168 to 8191 | r | Register Set Protocol (RSP) |

The following figure show the structure of the EEPROM:

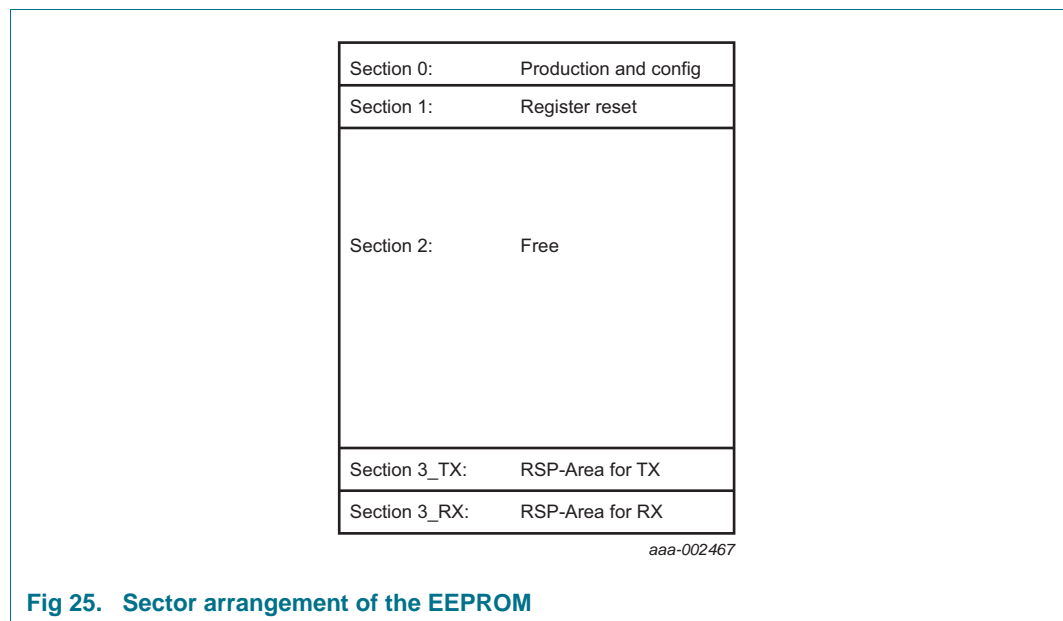

8.7.2.1 Product information and configuration - Page 0

The first EEPROM page includes production data as well as configuration information.

Table 27. Production area (Page 0)

| Address (Hex.) | 0 | 1 | 2 | 3 | 4 | 5 | 6 | 7 |
|----------------|-------------------|---|---|---------|-------------------|---|---|-------------------|
| 00 | ProductID | | | Version | Unique Identifier | | | |
| 08 | Unique Identifier | | | | | | | Manufacturer Data |
| 10 | ManufacturerData | | | | | | | |
| 18 | ManufacturerData | | | | | | | |

ProductID: Identifier for this SLRC610 product, only address 01h shall be evaluated for identifying the Product CLRC663, address 00h and 02h shall be ignored by software.

Table 28. Product ID overview of CLRC663 family

| Address 01h | Product ID |
|-------------|------------|
| CLRC663 | 01h |
| MFRC631 | C0h |
| MFRC630 | 80h |
| SLRC610 | 20h |

Version: This register indicates the version of the EEPROM initialization data during production. (Identification of the Hardware version is available in the register 7Fh, not in the EEPROM Version address. The hardware information in register 7Fh is hardwired and therefore independent from any EEPROM configuration.)

Unique identifier: Unique identifier for this device

Manufacturer Data: This data is programmed during production. The content is not intended to be used by any application and might be not the same for different devices. Therefore this content needs to be considered to be undefined.

Table 29. Configuration area (Page 0)

| Address (Hex.) | 0 | 1 | 2 | 3 | 4 | 5 | 6 | 7 |
|----------------|--------------------------|-----------|------------------------------|---------------|---------------|---|-------------|---|
| 20 | I ² C_Address | Interface | I ² C SAM_Address | DefaultProtRx | DefaultProtTx | - | TxCRCPreset | |
| 28 | RxCRCPreSet | - | - | - | - | - | - | - |
| 30 | - | | | | | | | |
| 38 | - | | | | | | | |

I²C-Address: Two possibilities exist to define the address of the I²C interface. This can be done either by configuring the pins IF0, IF2 (address is then 10101xx, xx is defined by the interface pins IF0, IF2) or by writing value into the I²C address area. The selection, which of this 2-information pin configuration or EEPROM content - is used as I²C-address is done at EEPROM address 21h (Interface, bit4)

Interface: This section describes the interface byte configuration.

Table 30. Interface byte

| Bit | 7 | 6 | 5 | 4 | 3 | 2 | 1 | 0 |
|---------------|----------------------|-----|-----|--------------------------|---------------|------|-----|---|
| | I ² C_HSP | - | - | I ² C_Address | Boundary Scan | Host | | |
| access rights | r/w | RFU | RFU | r/w | r/w | | r/w | |

Table 31. Interface bits

| Bit | Symbol | Description |
|--------|--------------------------|---|
| 7 | I ² C_HSP | when cleared, the high speed mode is used when set, the high speed+ mode is used (default) |
| 6, 5 | RFU | - |
| 4 | I ² C_Address | when cleared, the pins are used (default) when set, the EEPROM is used |
| 3 | Boundary Scan | when cleared, the boundary scan interface is ON (default) when set, the boundary scan is OFF |
| 2 to 0 | Host | 000b - RS232 001b - I ² C 010b - SPI 011b - I ² CL 1xxb - pin selection |

I²C_SAM_Address: The I²C SAM Address is always defined by the EEPROM content.

The Register Set Protocol (RSP) Area contains settings for the TX registers (16 bytes) and for the RX registers (8 bytes).

Table 32. Tx and Rx arrangements in the register set protocol area

| Section | | | | | | | | |
|--------------|-----|-----|------|------|------|------|------|------|
| Section 4 TX | Tx0 | | | Tx1 | | | TX2 | Tx3 |
| Section 4 TX | Tx4 | | | Tx5 | | | TX6 | TX7 |
| Section 4 Rx | RX0 | RX1 | RX2 | RX3 | RX4 | RX5 | RX6 | RX7 |
| Section 4 Rx | RX8 | RX9 | RX10 | RX11 | RX12 | RX13 | RX14 | RX15 |

TxCrcPreset: The data bits are send by the analog module and are automatically extended by a CRC.

8.7.3 EEPROM initialization content LoadProtocol

The SLRC610 EEPROM is initialized at production with values which are used to reset certain registers of the SLRC610 to default settings by copying the EEProm content to the registers. Only registers or bits with “read/write” or “dynamic” access rights are initialized with this default values copied from the EEProm.

Note that the addresses used for copying reset values from EEProm to registers are dependent on the configured protocol and can be changed by the user.

Table 33. Register reset values (Hex.) (Page0)

| Address | 0 (8) | 1 (9) | 2 (A) | 3 (B) | 4 (C) | 5 (D) | 6 (E) | 7 (F) |
|----------|----------------------|---------------------|---------|-------|----------------------|-------|-------|--------------------|
| Function | Product ID | | Version | | Unique Serial Number | | | |
| 00 | XX | see table 34 | XX | XX | XX | XX | XX | XX |
| Function | Unique Serial Number | | | | | | | Factory trim value |
| 08 | XX | XX | XX | XX | XX | XX | XX | XX |
| Function | TrimLFO | Factory trim values | | | | | | |
| 10 | XX | XX | XX | XX | XX | XX | XX | XX |
| Function | Factory trim values | | | | | | | |
| 18.... | XX | XX | XX | XX | XX | XX | XX | XX |
| Function | Factory trim values | | | | | | | |
|38 | XX | XX | XX | XX | XX | XX | XX | XX |

The register reset values are configuration parameters used after startup of the IC. They can be changed to modify the default behavior of the device. In addition to this register reset values, is the possibility to load settings for various user implemented protocols. The load protocol command is used for this purpose.

Table 34. Register reset values (Hex.)(Page1 and page 2)

| Address | 0 (8) | 1 (9) | 2 (A) | 3 (B) | 4 (C) | 5 (D) | 6 (E) | 7 (F) |
|---------|-----------------|-----------------|-----------------|-----------------|-----------------|-----------------|-----------------|-----------------|
| | Command | HostCtrl | FiFoControl | WaterLevel | FiFoLength | FiFoData | IRQ0 | IRQ1 |
| 40 | 40 | 00 | 80 | 05 | 00 | 00 | 00 | 00 |
| | IRQ0En | IRQ1En | Error | Status | RxBitCtrl | RxColl | TControl | T0Control |
| 48 | 10 | 00 | 00 | 00 | 00 | 00 | 00 | 00 |
| | T0ReloadHi | T0ReloadLo | T0Counter ValHi | T0Counter ValLo | T1Control | T1ReloadHi | T1ReloadLo | T1Counter ValHi |
| 50 | 00 | 80 | 00 | 00 | 00 | 00 | 80 | 00 |
| | T1Counter ValLo | T2Control | T2ReloadHi | T2ReloadLo | T2Counter ValHi | T2Counter ValLo | T3Control | T3ReloadHi |
| 58 | 00 | 00 | 00 | 80 | 00 | 00 | 00 | 00 |
| | T3ReloadLo | T3Counter ValHi | T3Counter ValHi | T4Control | T4ReloadHi | T4ReloadLo | T4Counter ValHi | T4Counter ValLo |
| 60 | 80 | 00 | 00 | 00 | 00 | 80 | 00 | 00 |

Table 34. Register reset values (Hex.)(Page1 and page 2) ...continued

| Address | 0 (8) | 1 (9) | 2 (A) | 3 (B) | 4 (C) | 5 (D) | 6 (E) | 7 (F) |
|---------|------------------|------------|---------------|---------------|--------------|--------------|-----------|--------------|
| | DrvMode | TxAmp | DrvCon | Txl | TxCRC Preset | RxCRC Preset | TxDataNum | TxModWith |
| 68 | 86 | 15 | 11 | 06 | 18 | 18 | 08 | 27 |
| | TxSym10 BurstLen | TxWaitCtrl | TxWaitLo | FrameCon | RxSofD | RxCtrl | RxWait | RxThres hold |
| 70 | 00 | C0 | 12 | CF | 00 | 04 | 90 | 3F |
| | Rcv | RxAAna | RFU | SerialSpeed | LFO_trimm | PLL_Ctrl | PLL_Div | LPCD_QMin |
| 78 | 12 | 0A | 00 | 7A | 80 | 04 | 20 | 48 |
| | LPCD_QMax | LPCD_IMin | LPCD_result_I | LPCD_result_Q | PadEn | PadOut | PadIn | SigOut |
| 80 | 12 | 88 | 00 | 00 | 00 | 00 | 00 | 00 |
| | TxBitMod | RFU | TxDataCon | TxDataMod | TxSymFreq | TxSym0H | TySym0L | TxSym1H |
| 88 | 20 | xx | 04 | 50 | 40 | 00 | 00 | 00 |

8.8 Clock generation

8.8.1 Crystal oscillator

The clock applied to the SLRC610 acts as time basis for generation of the carrier sent out at TX and for the quadrature mixer I and Q clock generation as well as for the coder and decoder of the synchronous system. Therefore stability of the clock frequency is an important factor for proper performance. To obtain highest performance, clock jitter has to be as small as possible. This is best achieved by using the internal oscillator buffer with the recommended circuitry.

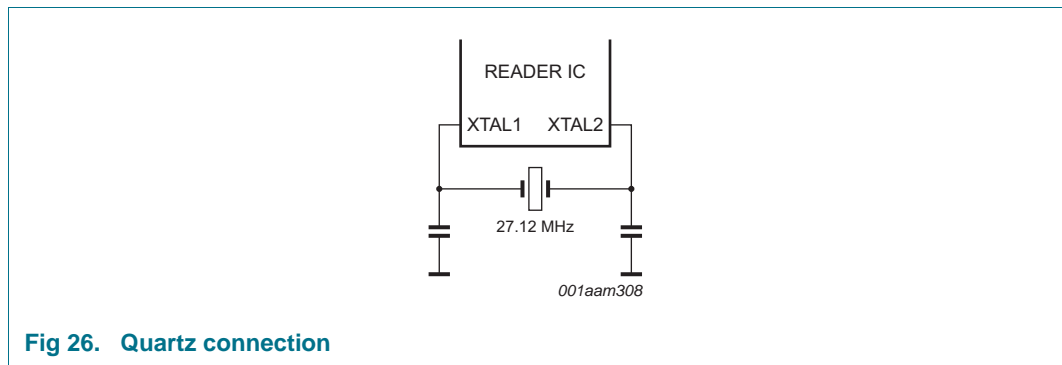

Fig 26. Quartz connection

Table 35. Crystal requirements recommendations

| Symbol | Parameter | Conditions | Min | Typ | max | Unit |
|----------------------------|--------------------------------------|------------|------|-------|------|----------|
| f_{xtal} | crystal frequency | | - | 27.12 | - | MHz |
| $\Delta f_{xtal}/f_{xtal}$ | relative crystal frequency variation | | -250 | - | +250 | ppm |
| ESR | equivalent series resistance | | - | 50 | 100 | Ω |
| C_L | load capacitance | | - | 10 | - | pF |
| P_{xtal} | crystal power dissipation | | - | 50 | 100 | μW |

8.8.2 IntegerN PLL clock line

The SLRC610 is able to provide a clock with configurable frequency at CLKOUT from 1 MHz to 24 MHz (PLL_Ctrl and PLL_DIV). There it can serve as a clock source to a microcontroller which avoids the need of a second crystal oscillator in the reader system. Clock source for the IntegerN-PLL is the 27.12 MHz crystal oscillator.

Two dividers are determining the output frequency. First a feedback integer-N divider configures the VCO frequency to be $N \times f_{in}/2$ (control signal pll_set_divfb). As supported Feedback Divider Ratios are 23, 27 and 28, VCO frequencies can be $23 \times f_{in} / 2$ (312 MHz), $27 \times f_{in} / 2$ (366 MHz) and $28 \times f_{in} / 2$ (380 MHz).

The VCO frequency is divided by a factor which is defined by the output divider (pll_set_divout). [Table 36 “Divider values for selected frequencies using the integerN PLL”](#) shows the accuracy achieved for various frequencies (integer multiples of 1 MHz and some typical RS232 frequencies) and the divider ratios to be used. The register bit ClkOutEn enables the clock at CLKOUT pin.

The following formula can be used to calculate the output frequency:

$$f_{\text{out}} = 13.56 \text{ MHz} \times \text{PLLDiv_FB} / \text{PLLDiv_Out}$$

Table 36. Divider values for selected frequencies using the integerN PLL

| | | | | | | | | | |
|-----------------|------|------|------|------|------|------|------|--------|--------|
| Frequency [MHz] | 4 | 6 | 8 | 10 | 12 | 20 | 24 | 1.8432 | 3.6864 |
| PLLDiv_FB | 23 | 27 | 23 | 28 | 23 | 28 | 23 | 28 | 28 |
| PLLDiv_Out | 78 | 61 | 39 | 38 | 26 | 19 | 16 | 206 | 103 |
| accuracy [%] | 0.04 | 0.03 | 0.04 | 0.08 | 0.04 | 0.08 | 0.04 | 0.01 | 0.01 |

8.8.3 Low Frequency Oscillator (LFO)

The Low-Frequency (LFO) is implemented to drive a wake-up counter (WUC). This wakes up the system in regular time intervals and eases the design of a reader that is regularly polling for card presence or implements a low-power card detection.

The LFO is trimmed during production to run at 16 KHz. Unless a high accuracy of the LFO is required by the application and the device is operated in an environment with changing ambient temperatures, trimming of the LFO is not required. For a typical application making use of the LFO for wake up from power down, the trim value set during production can be used. Optional trimming to achieve a higher accuracy of the 16 KHz LFO clock is supported by a digital state machine which compares LFO-clock to a reference clock. As reference clock frequency the 13.56 MHz crystal clock is available.

8.9 Power management

8.9.1 Supply concept

The SLRC610 is supplied by V_{DD} (Supply Voltage), PVDD (Pad Supply) and TVDD (Transmitter Power Supply). These three voltages are independent from each other.

To connect the SLRC610 to a Microcontroller supplied by 3.3 V, PVDD and V_{DD} shall be at a level of 3.3 V, TVDD can be in a range from 3.3 V to 5.0 V. A higher supply voltage at TVDD will result in a higher field strength.

Independent of the voltage it is recommended to buffer these supplies with blocking capacitances close to the terminals of the package. V_{DD} and PVDD are recommended to be blocked with a capacitor of 100 nF min, TVDD is recommended to be blocked with 2 capacitors, 100 nF parallel to 1.0 μ F

AVDD and DVDD are not supply input pins. They are output pins and shall be connected to blocking capacitors 470 nF each.

8.9.2 Power reduction mode

8.9.2.1 Power-down

A hard power-down is enabled with HIGH level on pin PDOWN. This turns off the internal 1.8 V voltage regulators for the analog and digital core supply as well as the oscillator. All digital input buffers are separated from the input pads and clamped internally (except pin PDOWN itself). The output pins are switched to high impedance.

To leave the power-down mode the level at the pin PDOWN as to be set to LOW. This will start the internal start-up sequence.

8.9.2.2 Standby mode

The standby mode is entered immediately after setting the bit PowerDown in the register Command. All internal current sinks are switched off except the LFO. Voltage references and voltage regulators will be set into stand-by mode.

In opposition to the power-down mode, the digital input buffers are not separated by the input pads and keep their functionality. The digital output pins do not change their state.

During standby mode, all registers values, the FIFO's content and the configuration itself will keep its current content.

To leave the standby mode the bit PowerDown in the register Command is cleared. This will trigger the internal start-up sequence. The reader IC is in full operation mode again when the internal start-up sequence is finalized (the typical duration is 15 μ s).

Alternatively, a value of 55h can be sent to the SLRC610 using the RS232 interface to leave the standby mode. Then read accesses shall be performed at address 00h until the device returns the content of this address. The return of the content of address 00h indicates that the device is ready to receive further commands and the internal start-up sequence is finalized.

8.9.2.3 Modem off mode

When the ModemOff bit in the register Control is set the antenna transmitter and the receiver are switched off.

To leave the modem off mode clears the ModemOff bit in the register Control.

8.9.3 Low-Power Card Detection (LPCD)

The low-power card detection is an energy saving mode in which the SLRC610 is not fully powered permanently.

The LPCD works in two phases. First the standby phase is controlled by the wake-up counter (WUC), which defines the duration of the standby of the SLRC610. Second phase is the detection-phase. In this phase the values of the I and Q channel are detected and stored in the register map. (LPCD_I_Result, LPCD_Q_Result). This time period can be handled with Timer3. The value is compared with the min/max values in the registers (LPCD_IMin, LPCD_IMax; LPCD_QMin, LPCD_QMax). If it exceeds the limits, a LPCDIrq is raised.

After the command LPCD the standby of the SLRC610 is activated, if selected. The wake-up Timer4 can activate the system after a given time. For the LPCD it is recommended to set T4AutoWakeUp and T4AutoRestart, to start the timer and then go to standby. If a card is detected the timer stops and the communication can be started. If T4AutoWakeUp is not set, the IC will not enter Standby mode in case no card is detected.

8.9.4 Reset and start-up time

A 10 μs constant high level at the PDOWN pin starts the internal reset procedure.

The following figure shows the internal voltage regulator:

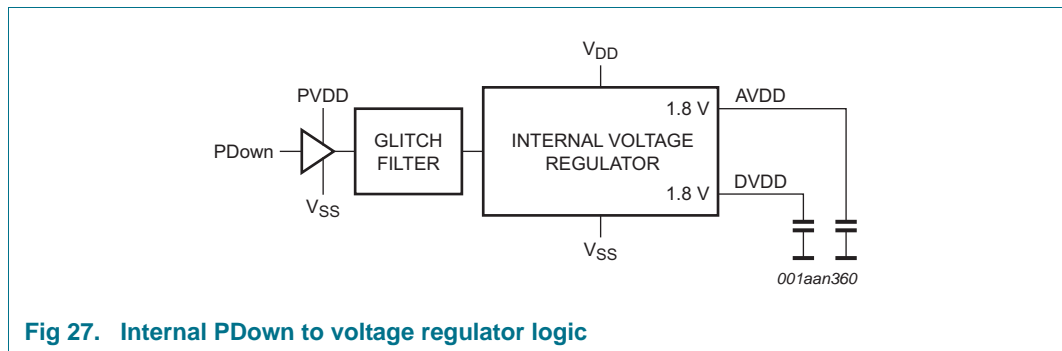

Fig 27. Internal PDown to voltage regulator logic

When the SLRC610 has finished the reset phase and the oscillator has entered a stable working condition the IC is ready to be used.

8.10 Command set

8.10.1 General

The behavior is determined by a state machine capable to perform a certain set of commands. By writing the according command-code to register Command the command is executed.

Arguments and/or data necessary to process a command, are exchanged via the FIFO buffer.

- A data transmission of the TxEncoder can be started by a command. When started, the communication is executed as defined in the TxFrameCon register. Therefore a communication frame can consist of a start-symbol, a data-stream, and followed by an end-symbol.
- Each command that needs a certain number of arguments will start processing only when it has received the correct number of arguments via the FIFO buffer.
- The FIFO buffer is not cleared automatically at command start. Therefore, it is recommended to write the command arguments and/or the data bytes into the FIFO buffer and start the command afterwards.
- Each command may be interrupted by the host by writing a new command code into register Command e.g.: the Idle-Command.

8.10.2 Command set overview

Table 37. Command set

| Command | No. | Parameter (bytes) | Short description |
|-------------|-----|--|---|
| Idle | 00h | - | no action, cancels current command execution |
| LPCD | 01h | - | low-power card detection |
| AckReq | 04h | - | performs a query, an Ack and a Req-Rn for ISO/IEC 18000-3 mode 3/ EPC Class-1 HF |
| Receive | 05h | - | activates the receive circuit |
| Transmit | 06h | - | transmits data from the FIFO buffer |
| Transceive | 07h | - | transmits data from the FIFO buffer and automatically activates the receiver after transmission finished |
| WriteE2 | 08h | addressL, addressH, data; | gets one byte from FIFO buffer and writes it to the internal EEPROM, valid address range are the addresses of the MIFARE Key area |
| WriteE2Page | 09h | (page Address), data0, [data1 ..data63]; | gets up to 64 bytes (one EEPROM page) from the FIFO buffer and writes it to the EEPROM, valid page address range are the pages of the MIFARE Key Area |
| ReadE2 | 0Ah | addressL, address H, length; | reads data from the EEPROM and copies it into the FIFO buffer, valid address range are the addresses of the MIFARE Key area |
| LoadReg | 0Ch | (EEPROM addressL), (EEPROM addressH), RegAdr, (number of Register to be copied); | reads data from the internal EEPROM and initializes the SLRC610 registers. EEPROM address needs to be within EEPROM sector 2 |

Table 37. Command set ...continued

| Command | No. | Parameter (bytes) | Short description |
|--------------|-----|---|--|
| LoadProtocol | 0Dh | (Protocol number RX), (Protocol number TX); | reads data from the internal EEPROM and initializes the SLRC610 registers needed for a Protocol change |
| ReadRNR | 1Ch | - | Copies bytes from the Random Number generator into the FIFO until the FiFo is full |
| Soft Reset | 1Fh | - | resets the SLRC610 |

8.10.3 Command functionality

8.10.3.1 Idle command

Command (00h);

This command indicates that the SLRC610 is in idle mode. This command is also used to terminate the actual command.

8.10.3.2 LPCD command

Command (01h);

This command performs a low-power card detection and or an automatic trimming of the LFO. The values of the sampled I and Q channel are stored in the register map. The value is compared with the min/max values in the register. If it exceeds the limits, an LPCD_Irq will be raised. After the command the standby is activated if selected.

8.10.3.3 AckReq command

Command (04h);

Performs a Query (Full command must be written into the FIFO); a Ack and a ReqRn command. All answers to the command will be written into the FIFO. The error flag is copied after the answer into the FIFO.

This command terminates automatically when finished and the active command is idle.

8.10.3.4 Receive command

Command (05h);

The SLRC610 activates the receiver path, waits for any data stream to be received, according to its register settings, which shall be set before starting this command according the used protocol and antenna configuration. The correct settings have to be chosen before starting this command.

This command terminates automatically when the received data stream ends. This is indicated either by the end of frame pattern or by the length byte depending on the selected framing and speed.

Remark: If the bit RxMultiple in the RxModeReg register is set to logic 1, the Receive command does not terminate automatically. It has to be terminated by activating any other command in the CommandReg register (see [Section 0.2.6 "RxMod"](#)).

8.10.3.5 Transmit command

Command (06h);

The content of the FIFO is transmitted immediately after starting the command. Before transmitting the FIFO content all relevant register have to be set to transmit data.

This command terminates automatically when the FIFO gets empty. It can be terminated by any other command written to the command register.

8.10.3.6 Transceive command

Command (07h);

This command transmits data from the FIFO and receives data from the RF field at once. The first action is transmitting and after a transmission the command is changed to receive a data stream.

Each transmission process starts by writing the command into CommandReg.

Remark: If the bit RxMultiple in register RxModeReg is set to logic 1, this command will never leave the receiving state, because the receiving will not be cancelled automatically.

8.10.3.7 WriteE2 command

Command (08h), Parameter1 (addressL), Parameter2 (addressH), Parameter3 (data);

This command writes one byte into the EEPROM. If the FIFO contains no data, the command will wait until the data is available.

Abort condition: insufficient parameter in FIFO; Address-parameter outside of range.

8.10.3.8 WriteE2PAGE command

Command (09h), Parameter1 (page address), Parameter2 (data0), Parameter3...65 [data1 ..data63];

This command writes up to 64 bytes into the EEPROM.

Abort condition: Insufficient parameters in FIFO; Page address parameter outside of range.

8.10.3.9 ReadE2 command

Command (0Ah), Parameter1 (addressL), Parameter2 (addressH), Parameter3 (length);

Reads up to 256 bytes from the EEPROM to the FIFO. If a read operation exceeds the address 1FFFh, the read operation continues from address 0000h.

Abort condition: Insufficient parameter in FIFO; Address parameter outside of range.

8.10.3.10 LoadReg command

Command (0Ch), Parameter1 (EEPROM addressL), Parameter2 (EEPROM addressH), Parameter3 (RegAdr), Parameter4 (number);

Read a defined number of bytes from the EEPROM and copies the value into the Register set, beginning at the given address RegAdr.

Abort condition: Insufficient parameter in FIFO; Address parameter outside of range.

8.10.3.11 LoadProtocol command

Command (0Dh), Parameter1 (Protocol number RX), Parameter2 (Protocol number TX);

Reads out the EEPROM Register Set Protocol Area and overwrites the content of the Rx- and Tx- related registers. These registers are important for a Protocol selection.

Abort condition: Insufficient parameter in FIFO

Table 38. Predefined protocol overview RX^[1]

| Protocol Number (decimal) | Protocol | Receiver speed [kbits/s] | Receiver Coding |
|---------------------------|---|--------------------------|-----------------|
| 00 | ISO/IEC15693 | 26 | SSC |
| 01 | ISO/IEC15693 | 52 | SSC |
| 02 | ISO/IEC15693 | 26 | DSC |
| 03 | EPC/UID | 26 | SSC |
| 04 | ISO/IEC 18000-3 mode 3/ EPC Class-1 HF | | 2/424 |
| 05 | ISO/IEC 18000-3 mode 3/ EPC Class-1 HF | | 4/424 |
| 06 | ISO/IEC 18000-3 mode 3/ EPC Class-1 HF | | 2/848 |
| 07 | ISO/IEC 18000-3 mode 3/ EPC Class-1 HF | | 4/848 |

[1] For more protocol details please refer to [Section 8 "Functional description"](#).

Table 39. Predefined protocol overview TX^[1]

| Protocol Number (decimal) | Protocol | Transmitter speed [kbits/s] | Transmitter Coding |
|---------------------------|---|-----------------------------|--------------------|
| 00 | ISO/IEC15693 | 26 | 1/4 |
| 01 | ISO/IEC15693 | 26 | 1/4 |
| 02 | ISO/IEC15693 | 1,66 | 1/256 |
| 03 | EPC/UID | 53 | Unitray |
| 04 | ISO/IEC 18000-3 mode 3/ EPC Class-1 HF | | Tari, ASK, PIE |
| 05 | ISO/IEC 18000-3 mode 3/ EPC Class-1 HF | | Tari, ASK, PIE |
| 06 | ISO/IEC 18000-3 mode 3/ EPC Class-1 HF | | Tari, ASK, PIE |
| 07 | ISO/IEC 18000-3 mode 3/ EPC Class-1 HF | | Tari, ASK, PIE |

[1] For more protocol details please refer to [Section 8 "Functional description"](#).

8.10.3.12 GetRNR command

Command (1Ch);

This command is reading Random Numbers from the random number generator of the SLRC610. The Random Numbers are copied to the FIFO until the FIFO is full.

8.10.3.13 SoftReset command

Command (1Fh);

This command is performing a soft reset. Triggered by this command all the default values for the register setting will be read from the EEPROM and copied into the register set.

9. SLRC610 registers

9.1 Register bit behavior

Depending on the functionality of a register, the access conditions to the register can vary. In principle, bits with same behavior are grouped in common registers. The access conditions are described in [Table 40](#).

Table 40. Behavior of register bits and their designation

| Abbreviation | Behavior | Description |
|--------------|----------------|--|
| r/w | read and write | These bits can be written and read via the host interface. Since they are used only for control purposes, the content is not influenced by the state machines but can be read by internal state machines. |
| dy | dynamic | These bits can be written and read via the host interface. They can also be written automatically by internal state machines, for example Command register changes its value automatically after the execution of the command. |
| r | read only | These register bits indicates hold values which are determined by internal states only. |
| w | write only | Reading these register bits always returns zero. |
| RFU | - | These bits are reserved for future use and must not be changed. In case of a required write access, it is recommended to write a logic 0. |

Table 41. SLRC610 registers overview

| Address | Register name | Function |
|---------|----------------|---|
| 00h | Command | Starts and stops command execution |
| 01h | HostCtrl | Host control register |
| 02h | FIFOControl | Control register of the FIFO |
| 03h | WaterLevel | Level of the FIFO underflow and overflow warning |
| 04h | FIFOLength | Length of the FIFO |
| 05h | FIFOData | Data In/Out exchange register of FIFO buffer |
| 06h | IRQ0 | Interrupt register 0 |
| 07h | IRQ1 | Interrupt register 1 |
| 08h | IRQ0En | Interrupt enable register 0 |
| 09h | IRQ1En | Interrupt enable register 1 |
| 0Ah | Error | Error bits showing the error status of the last command execution |
| 0Bh | Status | Contains status of the communication |
| 0Ch | RxBitCtrl | Control register for anticollision adjustments for bit oriented protocols |
| 0Dh | RxColl | Collision position register |
| 0Eh | TControl | Control of Timer 0..3 |
| 0Fh | T0Control | Control of Timer0 |
| 10h | T0ReloadHi | High register of the reload value of Timer0 |
| 11h | T0ReloadLo | Low register of the reload value of Timer0 |
| 12h | T0CounterValHi | Counter value high register of Timer0 |
| 13h | T0CounterValLo | Counter value low register of Timer0 |

Table 41. SLRC610 registers overview ...continued

| Address | Register name | Function |
|---------|-----------------|---|
| 14h | T1Control | Control of Timer1 |
| 15h | T1ReloadHi | High register of the reload value of Timer1 |
| 16h | T1ReloadLo | Low register of the reload value of Timer1 |
| 17h | T1CounterValHi | Counter value high register of Timer1 |
| 18h | T1CounterValLo | Counter value low register of Timer1 |
| 19h | T2Control | Control of Timer2 |
| 1Ah | T2ReloadHi | High byte of the reload value of Timer2 |
| 1Bh | T2ReloadLo | Low byte of the reload value of Timer2 |
| 1Ch | T2CounterValHi | Counter value high byte of Timer2 |
| 1Dh | T2CounterValLo | Counter value low byte of Timer2 |
| 1Eh | T3Control | Control of Timer3 |
| 1Fh | T3ReloadHi | High byte of the reload value of Timer3 |
| 20h | T3ReloadLo | Low byte of the reload value of Timer3 |
| 21h | T3CounterValHi | Counter value high byte of Timer3 |
| 22h | T3CounterValLo | Counter value low byte of Timer3 |
| 23h | T4Control | Control of Timer4 |
| 24h | T4ReloadHi | High byte of the reload value of Timer4 |
| 25h | T4ReloadLo | Low byte of the reload value of Timer4 |
| 26h | T4CounterValHi | Counter value high byte of Timer4 |
| 27h | T4CounterValLo | Counter value low byte of Timer4 |
| 28h | DrvMod | Driver mode register |
| 29h | TxAmp | Transmitter amplifier register |
| 2Ah | DrvCon | Driver configuration register |
| 2Bh | TxI | Transmitter register |
| 2Ch | TxCrcPreset | Transmitter CRC control register, preset value |
| 2Dh | RxCrcPreset | Receiver CRC control register, preset value |
| 2Eh | TxDatNum | Transmitter data number register |
| 2Fh | TxModWidth | Transmitter modulation width register |
| 30h | TxSym10BurstLen | Transmitter symbol 1 + symbol 0 burst length register |
| 31h | TXWaitCtrl | Transmitter wait control |
| 32h | TxWaitLo | Transmitter wait low |
| 33h | FrameCon | Transmitter frame control |
| 34h | RxSofD | Receiver start of frame detection |
| 35h | RxCtrl | Receiver control register |
| 36h | RxWait | Receiver wait register |
| 37h | RxThreshold | Receiver threshold register |
| 38h | Rcv | Receiver register |
| 39h | RxAna | Receiver analog register |
| 3Ah | RFU | - |
| 3Bh | SerialSpeed | Serial speed register |
| 3Ch | LFO_Trimm | Low-power oscillator trimming register |

Table 41. SLRC610 registers overview ...continued

| Address | Register name | Function |
|---------|---------------|--|
| 3Dh | PLL_Ctrl | IntegerN PLL control register, for microcontroller clock output adjustment |
| 3Eh | PLL_DivOut | IntegerN PLL control register, for microcontroller clock output adjustment |
| 3Fh | LPCD_QMin | Low-power card detection Q channel minimum threshold |
| 40h | LPCD_QMax | Low-power card detection Q channel maximum threshold |
| 41h | LPCD_I_Min | Low-power card detection I channel minimum threshold |
| 42h | LPCD_I_Result | Low-power card detection I channel result register |
| 43h | LPCD_Q_Result | Low-power card detection Q channel result register |
| 44h | PadEn | PIN enable register |
| 45h | PadOut | PIN out register |
| 46h | PadIn | PIN in register |
| 47h | SigOut | Enables and controls the SIGOUT Pin |
| 48h-5Fh | RFU | - |
| 7Fh | Version | Version and subversion register |

9.2 Command configuration

9.2.1 Command

Starts and stops command execution.

Table 42. Command register (address 00h)

| Bit | 7 | 6 | 5 | 4 | 3 | 2 | 1 | 0 |
|---------------|---------|-----------|-----|---------|---|---|---|---|
| Symbol | Standby | Modem Off | RFU | Command | | | | |
| Access rights | dy | r/w | - | dy | | | | |

Table 43. Command bits

| Bit | Symbol | Description |
|--------|----------|--|
| 7 | Standby | Set to 1, the IC is entering power-down mode. |
| 6 | ModemOff | Set to logic 1, the receiver and the transmitter circuit is powering down. |
| 5 | RFU | - |
| 4 to 0 | Command | Defines the actual command for the SLRC610. |

9.3 SAM configuration register

9.3.1 HostCtrl

Via the HostCtrl Register the interface access right can be controlled

Table 44. HostCtrl register (address 01h);

| Bit | 7 | 6 | 5 | 4 | 3 | 2 | 1 | 0 |
|---------------|-------|---------|--------|-----|--------------|--------------|-----|-----|
| Symbol | RegEn | BusHost | BusSAM | RFU | SAMInterface | SAMInterface | RFU | RFU |
| Access rights | dy | r/w | r/w | - | r/w | r/w | - | - |

Table 45. HostCtrl bits

| Bit | Symbol | Description |
|--------|--------------|---|
| 7 | RegEn | If this bit is set to logic 1, the register can be changed at the next register access. The next write access clears this bit automatically. |
| 6 | BusHost | Set to logic 1, the bus control enables the host interface. This bit cannot be set together with BusSAM. This bit can only be set if the bit RegEn is previously set. |
| 5 | BusSAM | Set to logic 1, the bus control enables the SAM interface. This bit cannot be set together with BusHost. This bit can only be set if the bit RegEn is previously set. |
| 4 | RFU | - |
| 3 to 2 | SAMInterface | 0h:Interface switched off 1h:Interface SPI active 2h:Interface I ² CL active 3h:Interface I ² C |
| 1 to 0 | RFU | - |

9.4 FIFO configuration register

9.4.1 FIFOControl

FIFOControl defines the characteristics of the FIFO

Table 46. FIFOControl register (address 02h);

| Bit | 7 | 6 | 5 | 4 | 3 | 2 | 1 | 0 |
|---------------|----------|---------|---------|-----------|-----|------------|------------|---|
| Symbol | FIFOSize | HiAlert | LoAlert | FIFOFlush | RFU | WaterLevel | FIFOLength | |
| Access rights | r/w | r | r | w | - | r/w | r | |

Table 47. FIFOControl bits

| Bit | Symbol | Description |
|--------|------------|--|
| 7 | FIFOSize | Set to logic 1, FIFO size is 255 bytes; Set to logic 0, FIFO size is 512 bytes. It is recommended to change the FIFO size only, when the FIFO content had been cleared. |
| 6 | HiAlert | Set to logic 1, when the number of bytes stored in the FIFO buffer fulfils the following equation: $HiAlert = (FIFOSize - FIFOLength) \leq WaterLevel$ |
| 5 | LoAlert | Set to logic 1, when the number of bytes stored in the FIFO buffer fulfils the following conditions: $LoAlert = 1$ if $FIFOLength \leq WaterLevel$ |
| 4 | FIFOFlush | Set to logic 1 empties the FIFO buffer. Reading this bit will always return 0 |
| 3 | RFU | - |
| 2 | WaterLevel | Defines the bit 8 (MSB) for the waterlevel (extension of WaterLevel). This bit is only evaluated in the 512-byte FIFO mode. Bits 7..0 are defined in WaterLevel. |
| 1 to 0 | FIFOLength | Defines the bit9 (MSB) and bit8 for the FIFO length (extension of FIFOLength). These two bits are only evaluated in the 512-byte FIFO mode, The bits 7..0 are defined in FIFOLength. |

9.4.2 WaterLevel

Defines the level for FIFO under- and overflow warning levels. This register is extended by 1 bit in FIFOControl in case the 512-byte FIFO mode is activated by setting bit FIFOControl.FIFOSize.

Table 48. WaterLevel register (address 03h);

| Bit | 7 | 6 | 5 | 4 | 3 | 2 | 1 | 0 |
|---------------|------------|---|---|---|---|---|---|---|
| Symbol | WaterLevel | | | | | | | |
| Access rights | r/w | | | | | | | |

Table 49. WaterLevel bits

| Bit | Symbol | Description |
|--------|------------|---|
| 7 to 0 | WaterLevel | <p>Sets a level to indicate a FIFO-buffer state which can be read from bits HighAlert and LowAlert in the FifoControl. In 512-byte FIFO mode, the register is extended by bit WaterLevel in the FIFOControl. This functionality can be used to avoid a FIFO buffer overflow or underflow:</p> <p>The bit HiAlert bit in FIFO Control is read logic 1, if the number of bytes in the FIFO-buffer is equal or less than the number defined by WaterLevel.</p> <p>The bit LoAlert bit in FIFO control is read logic 1, if the number of bytes in the FIFO buffer is equal or less than the number defined by WaterLevel.</p> <p>Note: For the calculation of HiAlert and LoAlert see register description of these bits (Section 9.4.1 "FIFOControl").</p> |

9.4.3 FIFOLength

Number of bytes in the FIFO buffer. In 512-byte mode this register is extended by FIFOControl.FifoLength.

Table 50. FIFOLength register (address 04h); reset value: 00h

| Bit | 7 | 6 | 5 | 4 | 3 | 2 | 1 | 0 |
|---------------|------------|---|---|---|---|---|---|---|
| Symbol | FIFOLength | | | | | | | |
| Access rights | dy | | | | | | | |

Table 51. FIFOLength bits

| Bit | Symbol | Description |
|--------|------------|---|
| 7 to 0 | FIFOLength | Indicates the number of bytes in the FIFO buffer. In 512-byte mode this register is extended by the bits FIFOLength in the FIFOControl register. Writing to the FIFOData register increments, reading decrements the number of available bytes in the FIFO. |

9.4.4 FIFOData

In- and output of FIFO buffer. Contrary to any read/write access to other addresses, reading or writing to the FIFO address does not increment the address pointer. Resulting in an efficient data transfer from and to the FIFO buffer. Writing to the FIFOData register increments, reading decrements the number of bytes present in the FIFO.

Table 52. FIFOData register (address 05h);

| Bit | 7 | 6 | 5 | 4 | 3 | 2 | 1 | 0 |
|---------------|----------|---|---|---|---|---|---|---|
| Symbol | FIFOData | | | | | | | |
| Access rights | dy | | | | | | | |

Table 53. FIFOData bits

| Bit | Symbol | Description |
|--------|----------|--|
| 7 to 0 | FIFOData | Data input and output port for the internal FIFO buffer. Refer to Section 8.5 "Buffer" . |

9.5 Interrupt configuration registers

The Registers IRQ0 register and IRQ1 register implement a special functionality to avoid the not intended modification of bits.

The mechanism of changing register contents requires the following consideration: IRQ(x). Set indicates, if a set bit on position 0 to 6 shall be cleared or set. Depending on the content of IRQ(x).Set, a write of a logical 1 to positions 0 to 6 either clears or sets the corresponding bit. With this register the application can modify the interrupt status which is maintained by the SLRC610.

Bit 7 indicates, if the intended modification is a setting or clearance of a bit. Any 1 written to a bit position 6...0 will trigger the setting or clearance of this bit as defined by bit 7. Example: writing FFh sets all bits 6..0, writing 7Fh clears all bits 6..0 of the interrupt request register

9.5.1 IRQ0 register

Interrupt request register 0.

Table 54. IRQ0 register (address 06h); reset value: 00h

| Bit | 7 | 6 | 5 | 4 | 3 | 2 | 1 | 0 |
|---------------|-----|-------------|-------------|---------|-------|-------|--------|-----------|
| Symbol | Set | Hi AlertIrq | Lo AlertIrq | IdleIrq | TxIrq | RxIrq | ErrIrq | RxSOF Irq |
| Access rights | w | dy | dy | dy | dy | dy | dy | dy |

Table 55. IRQ0 bits

| Bit | Symbol | Description |
|-----|------------|---|
| 7 | Set | 1: writing a 1 to a bit position 6..0 sets the interrupt request 0: Writing a 1 to a bit position 6..0 clears the interrupt request |
| 6 | HiAlertIrq | Set, when bit HiAlert in register Status1Reg is set. In opposition to HiAlert, HiAlertIrq stores this event and can only be reset if Set is cleared. |
| 5 | LoAlertIrq | Set, when bit LoAlert in register Status1 is set. In opposition to LoAlert, LoAlertIrq stores this event and can only be reset if Set is cleared |
| 4 | IdleIrq | Set, when a command terminates by itself e.g. when the Command changes its value from any command to the Idle command. If an unknown command is started, the Command changes its content to the idle state and the bit IdleIrq is set. Starting the Idle command by the Controller does not set bit IdleIrq. Can only be reset if Set is cleared. |
| 3 | TxIrq | Set, when data transmission is completed, which is immediately after the last bit is sent. Can only be reset if Set is cleared. |
| 2 | RxIrq | Set, when the receiver detects the end of a data stream. Note: This flag is no indication that the received data stream is correct. The error flags have to be evaluated to get the status of the reception. Can only be reset if Set is cleared. |
| 1 | ErrIrq | Set, when the one of the following errors is set: FifoWrErr, FiFoOvl, ProtErr, NoDataErr, IntegErr. Can only be reset if Set is cleared. |
| 0 | RxSOFIrq | Set, when a SOF or a subcarrier is detected. Can only be reset if Set is cleared. |

9.5.2 IRQ1 register

Interrupt request register 1.

Table 56. IRQ1 register (address 07h)

| Bit | 7 | 6 | 5 | 4 | 3 | 2 | 1 | 0 |
|---------------|-----|-----------|----------|-----------|-----------|-----------|-----------|-----------|
| Symbol | Set | GlobalIrq | LPCD_Irq | Timer4Irq | Timer3Irq | Timer2Irq | Timer1Irq | Timer0Irq |
| Access rights | w | dy | dy | dy | dy | dy | dy | dy |

Table 57. IRQ1 bits

| Bit | Symbol | Description |
|-----|-----------|--|
| 7 | Set | 1: writing a 1 to a bit position 5..0 sets the interrupt request 0: Writing a 1 to a bit position 5..0 clears the interrupt request |
| 6 | GlobalIrq | Set, if an enabled Irq occurs. |
| 5 | LPCD_Irq | Set if a card is detected in Low-power card detection sequence. |
| 4 | Timer4Irq | Set to logic 1 when Timer4 has an underflow. |
| 3 | Timer3Irq | Set to logic 1 when Timer3 has an underflow. |
| 2 | Timer2Irq | Set to logic 1 when Timer2 has an underflow. |
| 1 | Timer1Irq | Set to logic 1 when Timer1 has an underflow. |
| 0 | Timer0Irq | Set to logic 1 when Timer0 has an underflow. |

9.5.3 IRQ0En register

Interrupt request enable register for IRQ0. This register allows to define if an interrupt request is processed by the SLRC610.

Table 58. IRQ0En register (address 08h)

| Bit | 7 | 6 | 5 | 4 | 3 | 2 | 1 | 0 |
|---------------|---------|---------------|--------------|-----------|---------|---------|----------|------------|
| Symbol | Irq_Inv | Hi AlertIrqEn | LoAlertIrqEn | IdleIrqEn | TxIrqEn | RxIrqEn | ErrIrqEn | RxSOFIrqEn |
| Access rights | r/w | r/w | r/w | r/w | r/w | r/w | r/w | r/w |

Table 59. IRQ0En bits

| Bit | Symbol | Description |
|-----|---------------|--|
| 7 | Irq_Inv | Set to one the signal of the IRQ pin is inverted |
| 6 | Hi AlerIrqEn | Set to logic 1, it allows the High Alert interrupt Request (indicated by the bit HiAlertIrq) to be propagated to the GlobalIrq |
| 5 | Lo AlertIrqEn | Set to logic 1, it allows the Low Alert Interrupt Request (indicated by the bit LoAlertIrq) to be propagated to the GlobalIrq |
| 4 | IdleIrqEn | Set to logic 1, it allows the Idle interrupt request (indicated by the bit IdleIrq) to be propagated to the GlobalIrq |
| 3 | TxIRqEn | Set to logic 1, it allows the transmitter interrupt request (indicated by the bit TxIrq) to be propagated to the GlobalIrq |
| 2 | RxIRqEn | Set to logic 1, it allows the receiver interrupt request (indicated by the bit RxIrq) to be propagated to the GlobalIrq |
| 1 | ErrIRqEn | Set to logic 1, it allows the Error interrupt request (indicated by the bit ErrorIrq) to be propagated to the GlobalIrq |
| 0 | RxSOFIrqEn | Set to logic 1, it allows the RxSOF interrupt request (indicated by the bit RxSOFIrq) to be propagated to the GlobalIrq |

9.5.4 IRQ1En

Interrupt request enable register for IRQ1.

Table 60. IRQ1EN register (address 09h);

| Bit | 7 | 6 | 5 | 4 | 3 | 2 | 1 | 0 |
|---------------|-------------|----------|------------|-------------|-------------|-------------|-------------|-------------|
| Symbol | IrqPushPull | IrqPinEn | LPCD_IrqEn | Timer4IrqEn | Timer3IrqEn | Timer2IrqEn | Timer1IrqEn | Timer0IrqEn |
| Access rights | r/w | r/w | r/w | r/w | r/w | r/w | r/w | r/w |

Table 61. IRQ1EN bits

| Bit | Symbol | Description |
|-----|-------------|---|
| 7 | IrqPushPull | Set to 1 the IRQ-pin acts as PushPull pin, otherwise it acts as OpenDrain pin |
| 6 | IrqPinEN | Set to logic 1, it allows the global interrupt request (indicated by the bit Globallrq) to be propagated to the interrupt pin |
| 5 | LPCD_IrqEN | Set to logic 1, it allows the LPCDinterrupt request (indicated by the bit LPCDIrq) to be propagated to the Globallrq |
| 4 | Timer4IrqEn | Set to logic 1, it allows the Timer4 interrupt request (indicated by the bit Timer4Irq) to be propagated to the Globallrq |
| 3 | Timer3IrqEn | Set to logic 1, it allows the Timer3 interrupt request (indicated by the bit Timer3Irq) to be propagated to the Globallrq |
| 2 | Timer2IrqEn | Set to logic 1, it allows the Timer2 interrupt request (indicated by the bit Timer2Irq) to be propagated to the Globallrq |
| 1 | Timer1IrqEn | Set to logic 1, it allows the Timer1 interrupt request (indicated by the bit Timer1Irq) to be propagated to the Globallrq |
| 0 | Timer0IrqEn | Set to logic 1, it allows the Timer0 interrupt request (indicated by the bit Timer0Irq) to be propagated to the Globallrq |

9.6 Contactless interface configuration registers

9.6.1 Error

Error register.

Table 62. Error register (address 0Ah)

| Bit | 7 | 6 | 5 | 4 | 3 | 2 | 1 | 0 |
|---------------|--------|-----------|---------|-------------|-----------|---------|---------|----------|
| Symbol | EE_Err | FiFoWrErr | FIFOovl | MinFrameErr | NoDataErr | CollDet | ProtErr | IntegErr |
| Access rights | dy | dy | dy | dy | dy | dy | dy | dy |

Table 63. Error bits

| Bit | Symbol | Description |
|-----|-------------|--|
| 7 | EE_Err | An error appeared during the last EEPROM command. For details see the descriptions of the EEPROM commands |
| 6 | FIFOWrErr | Data was written into the FIFO, during a transmission of a possible CRC, during "RxWait", "Wait for data" or "Receiving" state, or during an authentication command. The Flag is cleared when a new CL command is started. If RxMultiple is active, the flag is cleared after the error flags have been written to the FIFO. |
| 5 | FIFOovl | Data is written into the FIFO when it is already full. The data that is already in the FIFO will remain untouched. All data that is written to the FIFO after this Flag is set to 1 will be ignored. |
| 4 | MinFrameErr | A valid SOF was received, but afterwards less than 4 bits of data were received. Note: Frames with less than 4 bits of data are automatically discarded and the RxDecoder stays enabled. Furthermore no RxIrq is set. The same is valid for less than 3 Bytes if the EMD suppression is activated Note: MinFrameErr is automatically cleared at the start of a receive or transceive command. In case of a transceive command, it is cleared at the start of the receiving phase ("Wait for data" state) |
| 3 | NoDataErr | Data should be sent, but no data is in FIFO |
| 2 | CollDet | A collision has occurred. The position of the first collision is shown in the register RxColl. Note: CollDet is automatically cleared at the start of a receive or transceive command. In case of a transceive command, it is cleared at the start of the receiving phase ("Wait for data" state). Note: If a collision is part of the defined EOF symbol, CollDet is not set to 1. |
| 1 | ProtErr | A protocol error has occurred. A protocol error can be a wrong stop bit or SOF or a wrong number of received data bytes. When a protocol error is detected, data reception is stopped. Note: ProtErr is automatically cleared at start of a receive or transceive command. In case of a transceive command, it is cleared at the start of the receiving phase ("Wait for data" state). Note: When a protocol error occurs the last received data byte is not written into the FIFO. |
| 0 | IntegErr | A data integrity error has been detected. Possible cause can be a wrong parity or a wrong CRC. In case of a data integrity error the reception is continued. Note: IntegErr is automatically cleared at start of a Receive or Transceive command. In case of a Transceive command, it is cleared at the start of the receiving phase ("Wait for data" state). Note: If the NoColl bit is set, also a collision is setting the IntegErr. |

9.6.2 Status

Status register.

Table 64. Status register (address 0Bh)

| Bit | 7 | 6 | 5 | 4 | 3 | 2 | 1 | 0 |
|---------------|-----|-----|-----|-----|-----|----------|---|---|
| Symbol | - | - | - | - | - | ComState | | |
| Access rights | RFU | RFU | RFU | RFU | RFU | r | | |

Table 65. Status bits

| Bit | Symbol | Description |
|--------|----------|---|
| 7 to 3 | - | RFU |
| 2 to 0 | ComState | ComState shows the status of the transmitter and receiver state machine: 000b ... Idle 001b ... TxWait 011b ... Transmitting 101b ... RxWait 110b ... Wait for data 111b ... Receiving 100b ... not used |

9.6.3 RxBitCtrl

Receiver control register.

Table 66. RxBitCtrl register (address 0Ch);

| Bit | 7 | 6 | 5 | 4 | 3 | 2 | 1 | 0 |
|---------------|-----------------|---------|---|--------|---|------------|---|---|
| Symbol | ValuesAfterColl | RxAlign | | NoColl | | RxLastBits | | |
| Access rights | r/w | r/w | | r/w | | w | | |

Table 67. RxBitCtrl bits

| Bit | Symbol | Description |
|-----|-----------------|--|
| 7 | ValuesAfterColl | If cleared, every received bit after a collision is replaced by a zero. This function is needed for ISO/IEC14443 anticollision |

Table 67. RxBitCtrl bits

| Bit | Symbol | Description |
|--------|------------|---|
| 6 to 4 | RxAlign | <p>Used for reception of bit oriented frames: RxAlign defines the bit position length for the first bit received to be stored. Further received bits are stored at the following bit positions.</p> <p>Example:</p> <p>RxAlign = 0h - the LSB of the received bit is stored at bit 0, the second received bit is stored at bit position 1.</p> <p>RxAlign = 1h - the LSB of the received bit is stored at bit 1, the second received bit is stored at bit position 2.</p> <p>RxAlign = 7h - the LSB of the received bit is stored at bit 7, the second received bit is stored in the following byte at position 0.</p> <p>Note: If RxAlign = 0, data is received byte-oriented, otherwise bit-oriented.</p> |
| 3 | NoColl | If this bit is set, a collision will result in an IntegErr |
| 2 to 0 | RxLastBits | <p>Defines the number of valid bits of the last data byte received in bit-oriented communications. If zero the whole byte is valid.</p> <p>Note: These bits are set by the RxDecoder in a bit-oriented communication at the end of the communication. They are reset at start of reception.</p> |

9.6.4 RxColl

Receiver collision register.

Table 68. RxColl register (address 0Dh);

| Bit | 7 | 6 | 5 | 4 | 3 | 2 | 1 | 0 |
|---------------|--------------|---------|---|---|---|---|---|---|
| Symbol | CollPosValid | CollPos | | | | | | |
| Access rights | r | r | | | | | | |

Table 69. RxColl bits

| Bit | Symbol | Description |
|--------|---------------|--|
| 7 | CollPos Valid | If set to 1, the value of CollPos is valid. Otherwise no collision is detected or the position of the collision is out of the range of bits CollPos. |
| 6 to 0 | CollPos | <p>These bits show the bit position of the first detected collision in a received frame (only data bits are interpreted). CollPos can only be displayed for the first 8 bytes of a data stream.</p> <p>Example:</p> <p>00h indicates a bit collision in the 1st bit</p> <p>01h indicates a bit collision in the 2nd bit</p> <p>08h indicates a bit collision in the 9th bit (1st bit of 2nd byte)</p> <p>3Fh indicates a bit collision in the 64th bit (8th bit of the 8th byte)</p> <p>These bits shall only be interpreted in ISO/IEC 15693/ICODE SLI read/write mode if bit CollPosValid is set.</p> <p>Note: If RxBitCtrl.RxAlign is set to a value different to 0, this value is included in the CollPos.</p> <p>Example: RxAlign = 4h, a collision occurs in the 4th received bit (which is the last bit of that UID byte). The CollPos = 7h in this case.</p> |

9.7 Timer configuration registers

9.7.1 TControl

Control register of the timer section.

The TControl implements a special functionality to avoid the not intended modification of bits.

Bit 3..0 indicates, which bits in the positions 7..4 are intended to be modified.

Example: writing FFh sets all bits 7..4, writing F0h does not change any of the bits 7..4

Table 70. TControl register (address 0Eh)

| Bit | 7 | 6 | 5 | 4 | 3 | 2 | 1 | 0 |
|---------------|-----------|-----------|-----------|-----------|--------------------|--------------------|--------------------|--------------------|
| Symbol | T3Running | T2Running | T1Running | T0Running | T3Start StopNow | T2Start StopNow | T1Start StopNow | T0Start StopNow |
| Access rights | dy | dy | dy | dy | w | w | w | w |

Table 71. TControl bits

| Bit | Symbol | Description |
|-----|--------------------|--|
| 7 | T3Running | Indicates Timer3 is running. If the bit T3startStopNow is set/reset, this bit and the timer can be started/stopped |
| 6 | T2Running | Indicates Timer2 is running. If the bit T2startStopNow is set/reset, this bit and the timer can be started/stopped |
| 5 | T1Running | Indicates tTmer1 is running. If the bit T1startStopNow is set/reset, this bit and the timer can be started/stopped |
| 4 | T0Running | Indicates Timer0 is running. If the bit T0startStopNow is set/reset, this bit and the timer can be started/stopped |
| 3 | T3StartStop Now | The bit 7 of TControl T3Running can be modified if set |
| 2 | T2StartStop Now | The bit 6 of TControl T2Running can be modified if set |
| 1 | T1StartStop Now | The bit 5 of TControl T1Running can be modified if set |
| 0 | T0StartStop Now | The bit 4 of TControl T0Running can be modified if set |

9.7.2 T0Control

Control register of the Timer0.

Table 72. T0Control register (address 0Fh);

| Bit | 7 | 6 | 5 | 4 | 3 | 2 | 1 | 0 |
|---------------|----------|-----|---------|---|---------------|-----|-------|---|
| Symbol | T0StopRx | - | T0Start | | T0AutoRestart | - | T0Clk | |
| Access rights | r/w | RFU | r/w | | r/w | RFU | r/w | |

Table 73. T0Control bits

| Bit | Symbol | Description |
|--------|---------------|--|
| 7 | T0StopRx | If set, the timer stops immediately after receiving the first 4 bits. If cleared the timer does not stop automatically. Note: If LFO Trimming is selected by T0Start, this bit has no effect. |
| 6 | - | RFU |
| 5 to 4 | T0Start | 00b: The timer is not started automatically 01b: The timer starts automatically at the end of the transmission 10b: Timer is used for LFO trimming without underflow (Start/Stop on PosEdge) 11b: Timer is used for LFO trimming with underflow (Start/Stop on PosEdge) |
| 3 | T0AutoRestart | 1: the timer automatically restarts its count-down from T0ReloadValue, after the counter value has reached the value zero. 0: the timer decrements to zero and stops. The bit Timer1Irq is set to logic 1 when the timer underflows. |
| 2 | - | RFU |
| 1 to 0 | T0Clk | 00b: The timer input clock is 13.56 MHz. 01b: The timer input clock is 211,875 kHz. 10b: The timer input clock is an underflow of Timer2. 11b: The timer input clock is an underflow of Timer1. |

9.7.2.1 T0ReloadHi

High byte reload value of the Timer0.

Table 74. T0ReloadHi register (address 10h);

| Bit | 7 | 6 | 5 | 4 | 3 | 2 | 1 | 0 |
|---------------|-------------|---|---|---|---|---|---|---|
| Symbol | T0Reload Hi | | | | | | | |
| Access rights | r/w | | | | | | | |

Table 75. T0ReloadHi bits

| Bit | Symbol | Description |
|--------|------------|--|
| 7 to 0 | T0ReloadHi | Defines the high byte of the reload value of the timer. With the start event the timer loads the value of the registers T0ReloadValHi, T0ReloadValLo. Changing this register affects the timer only at the next start event. |

9.7.2.2 T0ReloadLo

Low byte reload value of the Timer0.

Table 76. T0ReloadLo register (address 11h);

| Bit | 7 | 6 | 5 | 4 | 3 | 2 | 1 | 0 |
|---------------|------------|---|---|---|---|---|---|---|
| Symbol | T0ReloadLo | | | | | | | |
| Access rights | r/w | | | | | | | |

Table 77. T0ReloadLo bits

| Bit | Symbol | Description |
|--------|------------|---|
| 7 to 0 | T0ReloadLo | Defines the low byte of the reload value of the timer. With the start event the timer loads the value of the T0ReloadValHi, T0ReloadValLo. Changing this register affects the timer only at the next start event. |

9.7.2.3 T0CounterValHi

High byte of the counter value of Timer0.

Table 78. T0CounterValHi register (address 12h)

| Bit | 7 | 6 | 5 | 4 | 3 | 2 | 1 | 0 |
|---------------|----------------|---|---|---|---|---|---|---|
| Symbol | T0CounterValHi | | | | | | | |
| Access rights | dy | | | | | | | |

Table 79. T0CounterValHi bits

| Bit | Symbol | Description |
|------|----------------|--|
| 7to0 | T0CounterValHi | High byte value of the Timer0. This value shall not be read out during reception. |

9.7.2.4 T0CounterValLo

Low byte of the counter value of Timer0.

Table 80. T0CounterValLo register (address 13h)

| Bit | 7 | 6 | 5 | 4 | 3 | 2 | 1 | 0 |
|---------------|----------------|---|---|---|---|---|---|---|
| Symbol | T0CounterValLo | | | | | | | |
| Access rights | dy | | | | | | | |

Table 81. T0CounterValLo bits

| Bit | Symbol | Description |
|--------|----------------|---|
| 7 to 0 | T0CounterValLo | Low byte value of the Timer0. This value shall not be read out during reception. |

9.7.2.5 T1Control

Control register of the Timer1.

Table 82. T1Control register (address 14h);

| Bit | 7 | 6 | 5 | 4 | 3 | 2 | 1 | 0 |
|---------------|----------|-----|---------|---|---------------|---|-----|-------|
| Symbol | T1StopRx | - | T1Start | | T1AutoRestart | | - | T1Clk |
| Access rights | r/w | RFU | r/w | | r/w | | RFU | r/w |

Table 83. T1Control bits

| Bit | Symbol | Description |
|--------|---------------|--|
| 7 | T1StopRx | If set, the timer stops after receiving the first 4 bits. If cleared, the timer is not stopped automatically. Note: If LFO trimming is selected by T1start, this bit has no effect. |
| 6 | - | RFU |
| 5 to 4 | T1Start | 00b: The timer is not started automatically 01b: The timer starts automatically at the end of the transmission 10b: Timer is used for LFO trimming without underflow (Start/Stop on PosEdge) 11b: Timer is used for LFO trimming with underflow (Start/Stop on PosEdge) |
| 3 | T1AutoRestart | Set to logic 1, the timer automatically restarts its countdown from T1ReloadValue, after the counter value has reached the value zero. Set to logic 0 the timer decrements to zero and stops. The bit Timer1IRq is set to logic 1 when the timer underflows. |
| 2 | - | RFU |
| 1 to 0 | T1Clk | 00b: The timer input clock is 13.56 MHz 01b: The timer input clock is 211,875 kHz. 10b: The timer input clock is an underflow of Timer0 11b: The timer input clock is an underflow of Timer2 |

9.7.2.6 T1ReloadHi

High byte (MSB) reload value of the Timer1.

Table 84. T0ReloadHi register (address 15h)

| Bit | 7 | 6 | 5 | 4 | 3 | 2 | 1 | 0 |
|---------------|------------|---|---|---|---|---|---|---|
| Symbol | T1ReloadHi | | | | | | | |
| Access rights | r/w | | | | | | | |

Table 85. T1ReloadHi bits

| Bit | Symbol | Description |
|--------|------------|---|
| 7 to 0 | T1ReloadHi | Defines the high byte reload value of the Timer 1. With the start event the timer loads the value of the T1ReloadValHi and T1ReloadValLo. Changing this register affects the Timer only at the next start event. |

9.7.2.7 T1ReloadLo

Low byte (LSB) reload value of the Timer1.

Table 86. T1ReloadLo register (address 16h)

| Bit | 7 | 6 | 5 | 4 | 3 | 2 | 1 | 0 |
|---------------|------------|---|---|---|---|---|---|---|
| Symbol | T1ReloadLo | | | | | | | |
| Access rights | r/w | | | | | | | |

Table 87. T1ReloadValLo bits

| Bit | Symbol | Description |
|--------|------------|--|
| 7 to 0 | T1ReloadLo | Defines the low byte of the reload value of the Timer1. Changing this register affects the timer only at the next start event. |

9.7.2.8 T1CounterValHi

High byte (MSB) of the counter value of byte Timer1.

Table 88. T1CounterValHi register (address 17h)

| Bit | 7 | 6 | 5 | 4 | 3 | 2 | 1 | 0 |
|---------------|----------------|---|---|---|---|---|---|---|
| Symbol | T1CounterValHi | | | | | | | |
| Access rights | dy | | | | | | | |

Table 89. T1CounterValHi bits

| Bit | Symbol | Description |
|--------|----------------|--|
| 7 to 0 | T1CounterValHi | High byte of the current value of the Timer1. This value shall not be read out during reception. |

9.7.2.9 T1CounterValLo

Low byte (LSB) of the counter value of byte Timer1.

Table 90. T1CounterValLo register (address 18h)

| Bit | 7 | 6 | 5 | 4 | 3 | 2 | 1 | 0 |
|---------------|----------------|---|---|---|---|---|---|---|
| Symbol | T1CounterValLo | | | | | | | |
| Access rights | dy | | | | | | | |

Table 91. T1CounterValLo bits

| Bit | Symbol | Description |
|--------|----------------|--|
| 7 to 0 | T1CounterValLo | Low byte of the current value of the counter 1. This value shall not be read out during reception. |

9.7.2.10 T2Control

Control register of the Timer2.

Table 92. T2Control register (address 19h)

| Bit | 7 | 6 | 5 | 4 | 3 | 2 | 1 | 0 |
|---------------|----------|-----|---------|---|---------------|-----|-------|---|
| Symbol | T2StopRx | - | T2Start | | T2AutoRestart | - | T2Clk | |
| Access rights | r/w | RFU | r/w | | r/w | RFU | r/w | |

Table 93. T2Control bits

| Bit | Symbol | Description |
|--------|---------------|--|
| 7 | T2StopRx | If set the timer stops immediately after receiving the first 4 bits. If cleared indicates, that the timer is not stopped automatically. Note: If LFO Trimming is selected by T2Start, this bit has no effect. |
| 6 | - | RFU |
| 5 to 4 | T2Start | 00b: The timer is not started automatically. 01b: The timer starts automatically at the end of the transmission. 10b: Timer is used for LFO trimming without underflow (Start/Stop on PosEdge). 11b: Timer is used for LFO trimming with underflow (Start/Stop on PosEdge). |
| 3 | T2AutoRestart | Set to logic 1, the timer automatically restarts its countdown from T2ReloadValue, after the counter value has reached the value zero. Set to logic 0 the timer decrements to zero and stops. The bit Timer2IRq is set to logic 1 when the timer underflows |
| 2 | - | RFU |
| 1 to 0 | T2Clk | 00b: The timer input clock is 13.56 MHz. 01b: The timer input clock is 212 kHz. 10b: The timer input clock is an underflow of Timer0 11b: The timer input clock is an underflow of Timer1 |

9.7.2.11 T2ReloadHi

High byte of the reload value of Timer2.

Table 94. T2ReloadHi register (address 1Ah)

| Bit | 7 | 6 | 5 | 4 | 3 | 2 | 1 | 0 |
|---------------|------------|---|---|---|---|---|---|---|
| Symbol | T2ReloadHi | | | | | | | |
| Access rights | r/w | | | | | | | |

Table 95. T2Reload bits

| Bit | Symbol | Description |
|--------|------------|---|
| 7 to 0 | T2ReloadHi | Defines the high byte of the reload value of the Timer2. With the start event the timer load the value of the T2ReloadValHi and T2ReloadValLo. Changing this register affects the timer only at the next start event. |

9.7.2.12 T2ReloadLo

Low byte of the reload value of Timer2.

Table 96. T2ReloadLo register (address 1Bh)

| Bit | 7 | 6 | 5 | 4 | 3 | 2 | 1 | 0 |
|---------------|------------|---|---|---|---|---|---|---|
| Symbol | T2ReloadLo | | | | | | | |
| Access rights | r/w | | | | | | | |

Table 97. T2ReloadLo bits

| Bit | Symbol | Description |
|--------|------------|---|
| 7 to 0 | T2ReloadLo | Defines the low byte of the reload value of the Timer2. With the start event the timer load the value of the T2ReloadValHi and T2RelaodVaLo. Changing this register affects the timer only at the next start event. |

9.7.2.13 T2CounterValHi

High byte of the counter register of Timer2.

Table 98. T2CounterValHi register (address 1Ch)

| Bit | 7 | 6 | 5 | 4 | 3 | 2 | 1 | 0 |
|---------------|----------------|---|---|---|---|---|---|---|
| Symbol | T2CounterValHi | | | | | | | |
| Access rights | dy | | | | | | | |

Table 99. T2CounterValHi bits

| Bit | Symbol | Description |
|--------|----------------|---|
| 7 to 0 | T2CounterValHi | High byte current counter value of Timer2. This value shall not be read out during reception. |

9.7.2.14 T2CounterValLoReg

Low byte of the current value of Timer 2.

Table 100. T2CounterValLo register (address 1Dh)

| Bit | 7 | 6 | 5 | 4 | 3 | 2 | 1 | 0 |
|---------------|----------------|---|---|---|---|---|---|---|
| Symbol | T2CounterValLo | | | | | | | |
| Access rights | dy | | | | | | | |

Table 101. T2CounterValLo bits

| Bit | Symbol | Description |
|--------|----------------|---|
| 7 to 0 | T2CounterValLo | Low byte of the current counter value of Timer1Timer2. This value shall not be read out during reception. |

9.7.2.15 T3Control

Control register of the Timer 3.

Table 102. T3Control register (address 1Eh)

| Bit | 7 | 6 | 5 | 4 | 3 | 2 | 1 | 0 |
|---------------|----------|-----|---------|---|---------------|-----|-------|---|
| Symbol | T3StopRx | - | T3Start | | T3AutoRestart | - | T3Clk | |
| Access rights | r/w | RFU | r/w | | r/w | RFU | r/w | |

Table 103. T3Control bits

| Bit | Symbol | Description |
|--------|---------------|---|
| 7 | T3StopRx | If set, the timer stops immediately after receiving the first 4 bits. If cleared, indicates that the timer is not stopped automatically. Note: If LFO Trimming is selected by T3Start, this bit has no effect. |
| 6 | - | RFU |
| 5 to 4 | T3Start | 00b - timer is not started automatically 01b - timer starts automatically at the end of the transmission 10b - timer is used for LFO trimming without underflow (Start/Stop on PosEdge) 11b - timer is used for LFO trimming with underflow (Start/Stop on PosEdge). |
| 3 | T3AutoRestart | Set to logic 1, the timer automatically restarts its countdown from T3ReloadValue, after the counter value has reached the value zero. Set to logic 0 the timer decrements to zero and stops. The bit Timer1IRq is set to logic 1 when the timer underflows. |
| 2 | - | RFU |
| 1 to 0 | T3Clk | 00b - the timer input clock is 13.56 MHz. 01b - the timer input clock is 211,875 kHz. 10b - the timer input clock is an underflow of Timer0 11b - the timer input clock is an underflow of Timer1 |

9.7.2.16 T3ReloadHi

High byte of the reload value of Timer3.

Table 104. T3ReloadHi register (address 1Fh);

| Bit | 7 | 6 | 5 | 4 | 3 | 2 | 1 | 0 |
|---------------|------------|---|---|---|---|---|---|---|
| Symbol | T3ReloadHi | | | | | | | |
| Access rights | r/w | | | | | | | |

Table 105. T3ReloadHi bits

| Bit | Symbol | Description |
|--------|------------|---|
| 7 to 0 | T3ReloadHi | Defines the high byte of the reload value of the Timer3. With the start event the timer load the value of the T3ReloadValHi and T3ReloadValLo. Changing this register affects the timer only at the next start event. |

9.7.2.17 T3ReloadLo

Low byte of the reload value of Timer3.

Table 106. T3ReloadLo register (address 20h)

| Bit | 7 | 6 | 5 | 4 | 3 | 2 | 1 | 0 |
|---------------|------------|---|---|---|---|---|---|---|
| Symbol | T3ReloadLo | | | | | | | |
| Access rights | r/w | | | | | | | |

Table 107. T3ReloadLo bits

| Bit | Symbol | Description |
|--------|------------|--|
| 7 to 0 | T3ReloadLo | Defines the low byte of the reload value of Timer3. With the start event the timer load the value of the T3ReloadValHi and T3ReloadValLo. Changing this register affects the timer only at the next start event. |

9.7.2.18 T3CounterValHi

High byte of the current counter value the 16-bit Timer3.

Table 108. T3CounterValHi register (address 21h)

| Bit | 7 | 6 | 5 | 4 | 3 | 2 | 1 | 0 |
|---------------|----------------|---|---|---|---|---|---|---|
| Symbol | T3CounterValHi | | | | | | | |
| Access rights | dy | | | | | | | |

Table 109. T3CounterValHi bits

| Bit | Symbol | Description |
|--------|----------------|--|
| 7 to 0 | T3CounterValHi | High byte of the current counter value of Timer3. This value shall not be read out during reception. |

9.7.2.19 T3CounterValLo

Low byte of the current counter value the 16-bit Timer3.

Table 110. T3CounterValLo register (address 22h)

| Bit | 7 | 6 | 5 | 4 | 3 | 2 | 1 | 0 |
|---------------|----------------|---|---|---|---|---|---|---|
| Symbol | T3CounterValLo | | | | | | | |
| Access rights | dy | | | | | | | |

Table 111. T3CounterValLo bits

| Bit | Symbol | Description |
|--------|----------------|--|
| 7 to 0 | T3CounterValLo | Low byte current counter value of Timer3. This value shall not be read out during reception. |

9.7.2.20 T4Control

The wake-up timer T4 activates the system after a given time. If enabled, it can start the low power card detection function.

Table 112. T4Control register (address 23h)

| Bit | 7 | 6 | 5 | 4 | 3 | 2 | 1 | 0 |
|---------------|-----------|----------------|-------------|------------|---------------|--------------|-------|---|
| Symbol | T4Running | T4StartStopNow | T4AutoTrimm | T4AutoLPCD | T4AutoRestart | T4AutoWakeUp | T4Clk | |
| Access rights | dy | w | r/w | r/w | r/w | r/w | r/w | |

Table 113. T4Control bits

| Bit | Symbol | Description |
|--------|--------------------|---|
| 7 | T4Running | Shows if the timer T4 is running. If the bit T4StartStopNow is set, this bit and the timer T4 can be started/stopped. |
| 6 | T4Start StopNow | if set, the bit T4Running can be changed. |
| 5 | T4AutoTrimm | If set to one, the timer activates an LFO trimming procedure when it underflows. For the T4AutoTrimm function, at least one timer (T0 to T3) has to be configured properly for trimming (T3 is not allowed if T4AutoLPCD is set in parallel). |
| 4 | T4AutoLPCD | If set to one, the timer activates a low-power card detection sequence. If a card is detected an interrupt request is raised and the system remains active if enabled. If no card is detected the SLRC610 enters the Power down mode if enabled. The timer is automatically restarted (no gap). Timer 3 is used to specify the time where the RF field is enabled to check if a card is present. Therefore you may not use Timer 3 for T4AutoTrimm in parallel. |
| 3 | T4AutoRestart | Set to logic 1, the timer automatically restarts its countdown from T4ReloadValue, after the counter value has reached the value zero. Set to logic 0 the timer decrements to zero and stops. The bit Timer4Irq is set to logic 1 at timer underflow. |
| 2 | T4AutoWakeUp | If set, the SLRC610 wakes up automatically, when the timer T4 has an underflow. This bit has to be set if the IC should enter the Power down mode after T4AutoTrimm and/or T4AutoLPCD is finished and no card has been detected. If the IC should stay active after one of these procedures this bit has to be set to 0. |
| 1 to 0 | T4Clk | 00b - the timer input clock is the LFO clock 01b - the timer input clock is the LFO clock/8 10b - the timer input clock is the LFO clock/16 11b - the timer input clock is the LFO clock/32 |

9.7.2.21 T4ReloadHi

High byte of the reload value of the 16-bit timer 4.

Table 114. T4ReloadHi register (address 24h)

| Bit | 7 | 6 | 5 | 4 | 3 | 2 | 1 | 0 |
|---------------|------------|---|---|---|---|---|---|---|
| Symbol | T4ReloadHi | | | | | | | |
| Access rights | r/w | | | | | | | |

Table 115. T4ReloadHi bits

| Bit | Symbol | Description |
|--------|------------|--|
| 7 to 0 | T4ReloadHi | Defines high byte of the for the reload value of timer 4. With the start event the timer 4 loads the T4ReloadVal. Changing this register affects the timer only at the next start event. |

9.7.2.22 T4ReloadLo

Low byte of the reload value of the 16-bit timer 4.

Table 116. T4ReloadLo register (address 25h)

| Bit | 7 | 6 | 5 | 4 | 3 | 2 | 1 | 0 |
|---------------|------------|---|---|---|---|---|---|---|
| Symbol | T4ReloadLo | | | | | | | |
| Access rights | r/w | | | | | | | |

Table 117. T4ReloadLo bits

| Bit | Symbol | Description |
|--------|------------|--|
| 7 to 0 | T4ReloadLo | Defines the low byte of the reload value of the timer 4. With the start event the timer loads the value of the T4ReloadVal. Changing this register affects the timer only at the next start event. |

9.7.2.23 T4CounterValHi

High byte of the counter value of the 16-bit timer 4.

Table 118. T4CounterValHi register (address 26h)

| Bit | 7 | 6 | 5 | 4 | 3 | 2 | 1 | 0 |
|---------------|----------------|---|---|---|---|---|---|---|
| Symbol | T4CounterValHi | | | | | | | |
| Access rights | dy | | | | | | | |

Table 119. T4CounterValHi bits

| Bit | Symbol | Description |
|--------|----------------|--|
| 7 to 0 | T4CounterValHi | High byte of the current counter value of timer 4. |

9.7.2.24 T4CounterValLo

Low byte of the counter value of the 16-bit timer 4.

Table 120. T4CounterValLo register (address 27h)

| Bit | 7 | 6 | 5 | 4 | 3 | 2 | 1 | 0 |
|---------------|----------------|---|---|---|---|---|---|---|
| Symbol | T4CounterValLo | | | | | | | |
| Access rights | dy | | | | | | | |

Table 121. T4CounterValLo bits

| Bit | Symbol | Description |
|--------|----------------|---|
| 7 to 0 | T4CounterValLo | Low byte of the current counter value of the timer 4. |

9.8 Transmitter configuration registers

9.8.1 TxMode

Table 122. DrvMode register (address 28h)

| Bit | 7 | 6 | 5 | 4 | 3 | 2 | 1 | 0 |
|---------------|--------|--------|-----|-----|------|------------|---|---|
| Symbol | Tx2Inv | Tx1Inv | - | - | TxEn | TxClk Mode | | |
| Access rights | r/w | r/w | RFU | RFU | r/w | r/w | | |

Table 123. DrvMode bits

| Bit | Symbol | Description |
|--------|-----------|--|
| 7 | Tx2Inv | Inverts transmitter 2 at TX2 pin |
| 6 | Tx1Inv | Inverts transmitter 1 at TX1 pin |
| 5 | | RFU |
| 4 | - | RFU |
| 3 | TxEn | If set to 1 both transmitter pins are enabled |
| 2 to 0 | TxCikMode | Transmitter clock settings (see 8.6.2. Table 27). Codes 011b and 0b110 are not supported. This register defines, if the output is operated in open drain, push-pull, at high impedance or pulled to a fix high or low level. |

9.8.2 TxAmp

With the set_cw_amplitude register output power can be traded off against power supply rejection. Spending more headroom leads to better power supply rejection ration and better accuracy of the modulation degree.

With CwMax set, the voltage of TX1 will be pulled to the maximum possible. This register overrides the settings made by set_cw_amplitude.

Table 124. TxAmp register (address 29h)

| Bit | 7 | 6 | 5 | 4 | 3 | 2 | 1 | 0 |
|---------------|------------------|---|-----|----------------------|---|---|---|---|
| Symbol | set_cw_amplitude | | - | set_residual_carrier | | | | |
| Access rights | r/w | | RFU | r/w | | | | |

Table 125. TxAmp bits

| Bit | Symbol | Description |
|--------|----------------------|--|
| 7 to 6 | set_cw_amplitude | Allows to reduce the output amplitude of the transmitter by a fix value. Four different preset values that are subtracted from TVDD can be selected: 0: TVDD -100 mV 1: TVDD -250 mV 2: TVDD -500 mV 3: TVDD -1000 mV |
| 5 | RFU | - |
| 4 to 0 | set_residual_carrier | Set the residual carrier percentage. refer to Section 8.6.2 |

9.8.3 TxCon

Table 126. TxCon register (address 2Ah)

| Bit | 7 | 6 | 5 | 4 | 3 | 2 | 1 | 0 |
|---------------|-------------|---|---|---|-------|-------|-------|---|
| Symbol | OvershootT2 | | | | CwMax | TxInv | TxSel | |
| Access rights | r/w | | | | r/w | r/w | r/w | |

Table 127. TxCon bits

| Bit | Symbol | Description |
|--------|-------------|--|
| 7 to 4 | OvershootT2 | Specifies the length (number of carrier clocks) of the additional modulation for overshoot prevention. Refer to Section 8.6.2.1 “Overshoot protection” |
| 3 | Cwmax | Set amplitude of continuous wave carrier to the maximum. If set, set_cw_amplitude in Register TxAmp has no influence on the continuous amplitude. |
| 2 | TxInv | If set, the resulting modulation signal defined by TxSel is inverted |
| 1 to 0 | TxSel | Defines which signal is used as source for modulation 00b ... no modulation 01b ... TxEnvelope 10b ... SigIn 11b ... RFU |

9.8.4 TxI

Table 128. TxI register (address 2Bh)

| Bit | 7 | 6 | 5 | 4 | 3 | 2 | 1 | 0 |
|---------------|-------------|---|---|---|--------------|---|---|---|
| Symbol | OvershootT1 | | | | tx_set_iLoad | | | |
| Access rights | r/w | | | | r/w | | | |

Table 129. TxI bits

| Bit | Symbol | Description |
|--------|--------------|--|
| 7 to 4 | OvershootT1 | Overshoot value for Timer1. Refer to Section 8.6.2.1 “Overshoot protection” |
| 3 to 0 | tx_set_iLoad | Factory trim value, sets the expected Tx load current. This value is used to control the modulation index in an optimized way dependent on the expected TX load current. |

9.9 CRC configuration registers

9.9.1 TxCrcPreset

Table 130. TXCrcPreset register (address 2Ch)

| Bit | 7 | 6 | 5 | 4 | 3 | 2 | 1 | 0 |
|---------------|-----|-------------|---|---|-----------|---|-------------|---------|
| Symbol | RFU | TXPresetVal | | | TxCRCType | | TxCRCInvert | TxCRCEn |
| Access rights | - | r/w | | | r/w | | r/w | r/w |

Table 131. TxCrcPreset bits

| Bit | Symbol | Description |
|--------|-------------|---|
| 7 | RFU | - |
| 6 to 4 | TXPresetVal | Specifies the CRC preset value for transmission (see Table 132). |
| 3 to 2 | TxCRCtype | Defines which type of CRC (CRC8/CRC16/CRC5) is calculated: <ul style="list-style-type: none"> • 00h -- CRC5 • 01h -- CRC8 • 02h -- CRC16 • 03h -- RFU |
| 1 | TxCRCInvert | if set, the resulting CRC is inverted and attached to the data frame (ISO/IEC 3309) |
| 0 | TxCRCEn | if set, a CRC is appended to the data stream |

Table 132. Transmitter CRC preset value configuration

| TXPresetVal[6...4] | CRC16 | CRC8 | CRC5 |
|--------------------|--------------|--------------|--------------|
| 0h | 0000h | 00h | 00h |
| 1h | 6363h | 12h | 12h |
| 2h | A671h | BFh | - |
| 3h | FFFEh | FDh | - |
| 4h | - | - | - |
| 5h | - | - | - |
| 6h | User defined | User defined | User defined |
| 7h | FFFFh | FFh | 1Fh |

Remark: User defined CRC preset values can be configured by EEprom (see [Section 8.7.2.1](#), [Table 29 “Configuration area \(Page 0\)”](#)).

9.9.2 RxCrcCon

Table 133. RxCrcCon register (address 2Dh)

| Bit | 7 | 6 | 5 | 4 | 3 | 2 | 1 | 0 |
|---------------|-----------------|-------------|---|---|-----------|---|-------------|---------|
| Symbol | RxForceCRCWrite | RXPresetVal | | | RXCRCtype | | RxCRCInvert | RxCRCEn |
| Access rights | r/w | r/w | | | r/w | | r/w | r/w |

Table 134. RxCrcCon bits

| Bit | Symbol | Description |
|--------|------------------|--|
| 7 | RxForceCrc Write | If set, the received CRC byte(s) are copied to the FIFO. If cleared CRC Bytes are only checked, but not copied to the FIFO. This bit has to be always set in case of a not byte aligned CRC (e.g. ISO/IEC 18000-3 mode 3/ EPC Class-1HF) |
| 6 to 4 | RXPresetVal | Defines the CRC preset value (Hex.) for transmission. (see Table 135). |

Table 134. RxCrcCon bits

| Bit | Symbol | Description |
|--------|-------------|---|
| 3 to 2 | RxCRCtype | Defines which type of CRC (CRC8/CRC16/CRC5) is calculated: <ul style="list-style-type: none"> • 00h -- CRC5 • 01h -- CRC8 • 02h -- CRC16 • 03h -- RFU |
| 1 | RxCrcInvert | If set, the CRC check is done for the inverted CRC. |
| 0 | RxCrcEn | If set, the CRC is checked and in case of a wrong CRC an error flag is set. Otherwise the CRC is calculated but the error flag is not modified. |

Table 135. Receiver CRC preset value configuration

| RXPresetVal[6...4] | CRC16 | CRC8 | CRC5 |
|--------------------|--------------|--------------|--------------|
| 0h | 0000h | 00h | 00h |
| 1h | 6363h | 12h | 12h |
| 2h | A671h | BFh | - |
| 3h | FFFEh | FDh | - |
| 4h | - | - | - |
| 5h | - | - | - |
| 6h | User defined | User defined | User defined |
| 7h | FFFFh | FFh | 1Fh |

9.10 Transmitter configuration registers

9.10.1 TxDataNum

Table 136. TxDataNum register (address 2Eh)

| Bit | 7 | 6 | 5 | 4 | 3 | 2 | 1 | 0 |
|---------------|-----|------|------|-------------|--------|------------|---|---|
| Symbol | RFU | RFU- | RFU- | KeepBitGrid | DataEn | TxLastBits | | |
| Access rights | | | | r/w | r/w | r/w | | |

Table 137. TxDataNum bits

| Bit | Symbol | Description |
|--------|-------------|--|
| 7 to 5 | RFU | - |
| 4 | KeepBitGrid | If set, the time between consecutive transmissions starts is a multiple of one ETU. If cleared, consecutive transmissions can even start within one ETU |
| 3 | DataEn | If cleared - it is possible to send a single symbol pattern. If set - data is sent. |
| 2 to 0 | TxLastBits | Defines how many bits of the last data byte to be sent. If set to 000b all bits of the last data byte are sent. Note - bits are skipped at the end of the byte. Example - Data byte B2h (sent LSB first). TxLastBits = 011b (3h) => 010b (LSB first) is sent TxLastBits = 110b (6h) => 010011b (LSB first) is sent |

9.10.2 TxSym10BurstLen

If a protocol requires a burst (an unmodulated subcarrier) the length can be defined with this TxSymBurstLen, the value high or low can be defined by TxSym10BurstCtrl.

Table 138. TxSym10BurstLen register (address 30h)

| Bit | 7 | 6 | 5 | 4 | 3 | 2 | 1 | 0 |
|---------------|-----|---------------|---|---|-----|-----|---|---|
| Symbol | RFU | Sym1Burst Len | | | RFU | RFU | | |
| Access rights | - | r/w | | | - | - | | |

Table 139. TxSym10BurstLen bits

| Bit | Symbol | Description |
|--------|--------------|--|
| 7 | RFU | - |
| 6 to 4 | Sym1BurstLen | Specifies the number of bits issued for symbol 1 burst. The 3 bits encodes a range from 8 to 256 bit: 00h - 8bit 01h - 16bit 02h - 32bit 04h - 48bit 05h - 64bit 06h - 96bit 07h - 128bit 08h - 256bit |
| 3 to 0 | RFU | - |

9.10.3 TxWaitCtrl

Table 140. TxWaitCtrl register (address 31h); reset value: C0h

| Bit | 7 | 6 | 5 | 4 | 3 | 2 | 1 | 0 |
|---------------|-------------|-----------|-------------|---|---|-----|---|---|
| Symbol | TxWaitStart | TxWaitEtu | TxWait High | | | RFU | | |
| Access rights | r/w | r/w | r/w | | | - | | |

Table 141. TXWaitCtrl bits

| Bit | Symbol | Description |
|-----|-------------|--|
| 7 | TxWaitStart | If cleared, the TxWait time is starting at the End of the send data (TX). If set, the TxWait time is starting at the End of the received data (RX). |

Table 141. TXWaitCtrl bits

| Bit | Symbol | Description |
|--------|-----------------|--|
| 6 | TxWaitEtu | If cleared, the TxWait time is $TxWait \times 16/13.56$ MHz. If set, the TxWait time is $TxWait \times 0.5 / DBFreq$ (DBFreq is the frequency of the bit stream as defined by TxDataCon). |
| 5 to 3 | TxWait High | Bit extension of TxWaitLo. TxWaitCtrl bit 5 is MSB. |
| 2 to 0 | TxStopBitLength | Defines stop-bits and EGT (= stop-bit + extra guard time EGT) to be send: 0h: no stop-bit, no EGT 1h: 1 stop-bit, no EGT 2h: 1 stop-bit + 1 EGT 3h: 1 stop-bit + 2 EGT 4h: 1 stop-bit + 3 EGT 5h: 1 stop-bit + 4 EGT 6h: 1 stop-bit + 5 EGT 7h: 1 stop-bit + 6 EGT Note: This is only valid for ISO/IEC14443 Type B |

9.10.4 TxWaitLo

Table 142. TxWaitLo register (address 32h)

| Bit | 7 | 6 | 5 | 4 | 3 | 2 | 1 | 0 |
|---------------|----------|---|---|---|---|---|---|---|
| Symbol | TxWaitLo | | | | | | | |
| Access rights | r/w | | | | | | | |

Table 143. TxWaitLo bits

| Bit | Symbol | Description |
|--------|----------|--|
| 7 to 0 | TxWaitLo | <p>Defines the minimum time between receive and send or between two send data streams</p> <p>Note: TxWait is a 11bit register (additional 3 bits are in the TxWaitCtrl register)!</p> <p>See also TxWaitEtu and TxWaitStart.</p> |

9.11 FrameCon

Table 144. FrameCon register (address 33h)

| Bit | 7 | 6 | 5 | 4 | 3 | 2 | 1 | 0 |
|---------------|------------|------------|-----|-----|---------|---|----------|---|
| Symbol | TxParityEn | RxParityEn | - | - | StopSym | | StartSym | |
| Access rights | r/w | r/w | RFU | RFU | r/w | | r/w | |

Table 145. FrameCon bits

| Bit | Symbol | Description |
|--------|------------|---|
| 7 | TxParityEn | If set, a parity bit is calculated and appended to each byte transmitted. |
| 6 | RxParityEn | If set, the parity calculation is enabled. The parity is not transferred to the FIFO. |
| 5 to 4 | - | RFU |
| 3 to 2 | StopSym | <p>Defines which symbol is sent as stop-symbol:</p> <ul style="list-style-type: none"> • 0h: No symbol is sent • 1h: Symbol0 is sent • 2h symbol1 is sent • 3h Symbol2 is sent |
| 1 to 0 | StartSym | <p>Defines which symbol is sent as start-symbol:</p> <ul style="list-style-type: none"> • 0h: No Symbol is sent • 1h: Symbol0 is sent • 2h: Symbol1 is sent • 3h: Symbol2 is sent |

9.12 Receiver configuration registers

9.12.1 RxSofD

Table 146. RxSofD register (address 34h)

| Bit | 7 | 6 | 5 | 4 | 3 | 2 | 1 | 0 |
|---------------|-----|---|--------|-------------|-----|---------|---------------|--------------|
| Symbol | RFU | | SOF_En | SOFDetected | RFU | SubC_En | SubC_Detected | SubC_Present |
| Access rights | - | | r/w | dy | - | r/w | dy | r |

Table 147. RxSofD bits

| Bit | Symbol | Description |
|--------|---------------|---|
| 7 to 6 | RFU | - |
| 5 | SOF_En | If set and a SOF is detected an RxSOFIrq is raised. |
| 4 | SOF_Detected | Shows that a SOF is or was detected. Can be cleared by SW. |
| 3 | RFU | - |
| 2 | SubC_En | If set and a subcarrier is detected an RxSOFIrq is raised. |
| 1 | SubC_Detected | Shows that a subcarrier is or was detected. Can be cleared by SW. |
| 0 | SubC_Present | Shows that a subcarrier is currently detected. |

9.12.2 RxCtrl

Table 148. RxCtrl register (address 35h)

| Bit | 7 | 6 | 5 | 4 | 3 | 2 | 1 | 0 |
|---------------|-------------|------------|-----|-----|---------|----------|---|---|
| Symbol | RxAllowBits | RxMultiple | RFU | RFU | EMD_Sup | Baudrate | | |
| Access rights | r/w | r/w | - | - | r/w | r/w | | |

Table 149. RxCtrl bits

| Bit | Symbol | Description |
|--------|-------------|---|
| 7 | RxAllowBits | If set, data is written into FIFO even if CRC is enabled, and no complete byte has been received. |
| 6 | RxMultiple | If set, RxMultiple is activated and the receiver will not terminate automatically (refer Section 8.10.3.4 "Receive command"). If set to logic 1, at the end of a received data stream an error byte is added to the FIFO. The error byte is a copy of the Error register. |
| 5 to 4 | RFU | - |
| 3 | EMD_Sup | Enables the EMD suppression according ISO/IEC14443. If an error occurs within the first three bytes, these three bytes are assumed to be EMD, ignored and the FIFO is reset. A collision is treated as an error as well. If a valid SOF was received, the EMD_Sup is set and a frame of less than 3 bytes had been received. RX_IRq is not set in this EMD error cases. If RxForceCRCWrite is set, the FIFO should not be read out before three bytes are written into. |
| 2 to 0 | Baudrate | Defines the baud rate of the receiving signal. 2h: 26 kBd 3h: 52 kBd all remaining values are RFU |

9.12.3 RxWait

Selects internal receiver settings.

Table 150. RxWait register (address 36h)

| Bit | 7 | 6 | 5 | 4 | 3 | 2 | 1 | 0 | |
|---------------|-----------|--------|---|---|---|---|---|---|--|
| Symbol | RxWaitEtu | RxWait | | | | | | | |
| Access rights | r/w | r/w | | | | | | | |

Table 151. RxWait bits

| Bit | Symbol | Description |
|--------|-----------|---|
| 7 | RXWaitEtu | If set to 0, the RxWait time is $RxWait \times 16/13.56$ MHz. If set to 1, the RxWait time is $RxWait \times (0.5/DBFreq)$. |
| 6 to 0 | RxWait | Defines the time after sending, where every input is ignored. |

9.12.4 RxThreshold

Selects minimum threshold level for the bit decoder.

Table 152. RxThreshold register (address 37h)

| Bit | 7 | 6 | 5 | 4 | 3 | 2 | 1 | 0 |
|---------------|----------|---|---|---|-----------|---|---|---|
| Symbol | MinLevel | | | | MinLevelP | | | |
| Access rights | r/w | | | | r/w | | | |

Table 153. RxThreshold bits

| Bit | Symbol | Description |
|--------|-----------|---|
| 7 to 4 | MinLevel | Defines the MinLevel of the reception. Note: The MinLevel should be higher than the noise level in the system. |
| 3 to 0 | MinLevelP | Defines the MinLevel of the phase shift detector unit. |

9.12.5 Rcv

Table 154. Rcv register (address 38h)

| Bit | 7 | 6 | 5 | 4 | 3 | 2 | 1 | 0 |
|---------------|---------------|------------|----------|---|-----|---|-----------|---|
| Symbol | Rcv_Rx_single | Rx_ADCmode | SigInSel | | RFU | | CollLevel | |
| Access rights | r/w | r/w | r/w | | - | | r/w | |

Table 155. Rcv bits

| Bit | Symbol | Description |
|--------|---------------|--|
| 7 | Rcv_Rx_single | Single RXP Input Pin Mode; 0: Fully Differential 1: Quasi-Differential |
| 6 | Rx_ADCmode | Defines the operation mode of the Analog Digital Converter (ADC) 0: normal reception mode for ADC 1: LPCD mode for ADC |
| 5 to 4 | SigInSel | Defines input for the signal processing unit: 0h - idle 1h - internal analog block (RX) 2h - signal in over envelope (ISO/IEC14443A) 3h - signal in over s3c-generic |
| 3 to 2 | RFU | - |
| 1 to 0 | CollLevel | Defines the strength of a signal to be interpreted as a collision: 0h - Collision has at least 1/8 of signal strength 1h - Collision has at least 1/4 of signal strength 2h - Collision has at least 1/2 of signal strength 3h - Collision detection is switched off |

9.12.6 RxAna

This register allows to set the gain (rcv_gain) and high pass corner frequencies (rcv_hpcf).

Table 156. RxAna register (address 39h)

| Bit | 7 | 6 | 5 | 4 | 3 | 2 | 1 | 0 |
|---------------|------------|---|-----|---|----------|---|----------|---|
| Symbol | VMid_r_sel | | RFU | | rcv_hpcf | | rcv_gain | |
| Access rights | r/w | | - | | r/w | | r/w | |

Table 157. RxAna bits

| Bit | Symbol | Description |
|--------|------------|--|
| 7, 6 | VMid_r_sel | Factory trim value, needs to be 0. |
| 5, 4 | RFU | |
| 3, 2 | rcv_hpcf | The rcv_hpcf [1:0] signals allow 4 different settings of the base band amplifier lower cut-off frequency from ~40 kHz to ~300 kHz. |
| 1 to 0 | rcv_gain | With rcv_gain[1:0] four different gain settings from 30 dB and 60 dB can be configured (differential output voltage/differential input voltage). |

Table 158. Effect of gain and highpass corner register settings

| rcv_gain (Hex.) | rcv_hpcf (Hex.) | f _l (kHz) | f _U (MHz) | gain (dB20) | bandwidth (MHz) |
|-----------------|-----------------|----------------------|----------------------|-------------|-----------------|
| 03 | 00 | 38 | 2,3 | 60 | 2,3 |
| 03 | 01 | 79 | 2,4 | 59 | 2,3 |
| 03 | 02 | 150 | 2,6 | 58 | 2,5 |
| 03 | 03 | 264 | 2,9 | 55 | 2,6 |
| 02 | 00 | 41 | 2,3 | 51 | 2,3 |
| 02 | 01 | 83 | 2,4 | 50 | 2,3 |
| 02 | 02 | 157 | 2,6 | 49 | 2,4 |
| 02 | 03 | 272 | 3,0 | 41 | 2,7 |
| 01 | 00 | 42 | 2,6 | 43 | 2,6 |
| 01 | 01 | 84 | 2,7 | 42 | 2,6 |
| 01 | 02 | 157 | 2,9 | 41 | 2,7 |
| 01 | 03 | 273 | 3,3 | 39 | 3,0 |
| 00 | 00 | 43 | 2,6 | 35 | 2,6 |
| 00 | 01 | 85 | 2,7 | 34 | 2,6 |
| 00 | 02 | 159 | 2,9 | 33 | 2,7 |
| 00 | 03 | 276 | 3,4 | 30 | 3,1 |

9.13 Clock configuration

9.13.1 SerialSpeed

This register allows to set speed of the RS232 interface. The default speed is set to 9,6kbit/s. The transmission speed of the interface can be changed by modifying the entries for BR_T0 and BR_T1. The transfer speed can be calculated by using the following formulas:

$$BR_T0 = 0: \text{transfer speed} = 27.12 \text{ MHz} / (BR_T1 + 1)$$

$$BR_T0 > 0: \text{transfer speed} = 27.12 \text{ MHz} / (BR_T1 + 33) / 2^{(BR_T0 - 1)}$$

The framing is implemented with 1 startbit, 8 databits and 1 stop bit. A parity bit is not used. Transfer speeds above 1228,8 kbit/s are not supported.

Table 159. SerialSpeed register (address3Bh); reset value: 7Ah

| Bit | 7 | 6 | 5 | 4 | 3 | 2 | 1 | 0 |
|---------------|-------|---|---|-------|---|---|---|---|
| Symbol | BR_T0 | | | BR_T1 | | | | |
| Access rights | r/w | | | r/w | | | | |

Table 160. SerialSpeed bits

| Bit | Symbol | Description |
|--------|--------|--|
| 7 to 5 | BR_T0 | BR_T0 = 0: transfer speed = 27.12 MHz / (BR_T1 + 1) BR_T0 > 0: transfer speed = 27.12 MHz / (BR_T1 + 33) / 2 ^(BR_T0 - 1) |
| 4 to 0 | BR_T1 | BR_T0 = 0: transfer speed = 27.12 MHz / (BR_T1 + 1) BR_T0 > 0: transfer speed = 27.12 MHz / (BR_T1 + 33) / 2 ^(BR_T0 - 1) |

Table 161. RS232 speed settings

| Transfer speed (kbit/s) | SerialSpeed register content (Hex.) |
|-------------------------|-------------------------------------|
| 7,2 | FA |
| 9,6 | EB |
| 14,4 | DA |
| 19,2 | CB |
| 38,4 | AB |
| 57,6 | 9A |
| 115,2 | 7A |
| 128,0 | 74 |
| 230,4 | 5A |
| 460,8 | 3A |
| 921,6 | 1C |
| 1228,8 | 15 |

9.13.2 LFO_Trimm

Table 162. LFO_Trim register (address 3Ch)

| Bit | 7 | 6 | 5 | 4 | 3 | 2 | 1 | 0 |
|---------------|-----------|---|---|---|---|---|---|---|
| Symbol | LFO_trimm | | | | | | | |
| Access rights | r/w | | | | | | | |

Table 163. LFO_Trim bits

| Bit | Symbol | Description |
|--------|-----------|---|
| 7 to 0 | LFO_trimm | Trimm value. Refer to Section 8.8.3 “Low Frequency Oscillator (LFO)” Note: If the trimm value is increased, the frequency of the oscillator decreases. |

9.13.3 PLL_Ctrl Register

The PLL_Ctrl register implements the control register for the IntegerN PLL. Two stages exist to create the ClkOut signal from the 27,12MHz input. In the first stage the 27,12Mhz input signal is multiplied by the value defined in PLLDiv_FB and divided by two, and the second stage divides this frequency by the value defined by PLLDIV_Out.

Table 164. PLL_Ctrl register (address3Dh)

| Bit | 7 | 6 | 5 | 4 | 3 | 2 | 1 | 0 |
|---------------|-----------|---|---|---|-----------|--------|-----------|---|
| Symbol | ClkOutSel | | | | ClkOut_En | PLL_PD | PLLDiv_FB | |
| Access rights | r/w | | | | r/w | r/w | r/w | |

Table 165. PLL_Ctrl register bits

| Bit | Symbol | Description |
|--------|-----------|---|
| 7 to 4 | CLkOutSel | <ul style="list-style-type: none"> 0h - pin CLKOUT is used as I/O 1h - pin CLKOUT shows the output of the analog PLL 2h - pin CLKOUT is hold on 0 3h - pin CLKOUT is hold on 1 4h - pin CLKOUT shows 27.12 MHz from the crystal 5h - pin CLKOUT shows 13.56 MHz derived from the crystal 6h - pin CLKOUT shows 6.78 MHz derived from the crystal 7h - pin CLKOUT shows 3.39 MHz derived from the crystal 8h - pin CLKOUT is toggled by the Timer0 overflow 9h - pin CLKOUT is toggled by the Timer1 overflow Ah - pin CLKOUT is toggled by the Timer2 overflow Bh - pin CLKOUT is toggled by the Timer3 overflow Ch...Fh - RFU |
| 3 | ClkOut_En | Enables the clock at Pin CLKOUT |
| 2 | PLL_PD | PLL power down |
| 1-0 | PLLDiv_FB | PLL feedback divider (see table 174) |

Table 166. Setting of feedback divider PLLDiv_FB [1:0]

| Bit 1 | Bit 0 | Division |
|-------|-------|---------------------------|
| 0 | 0 | 23 (VCO frequency 312Mhz) |
| 0 | 1 | 27 (VCO frequency 366MHz) |
| 1 | 0 | 28 (VCO frequency 380Mhz) |
| 1 | 1 | 23 (VCO frequency 312Mhz) |

9.13.4 PLLDiv_Out

Table 167. PLLDiv_Out register (address 3Eh)

| Bit | 7 | 6 | 5 | 4 | 3 | 2 | 1 | 0 |
|---------------|------------|---|---|---|---|---|---|---|
| Symbol | PLLDiv_Out | | | | | | | |
| Access rights | r/w | | | | | | | |

Table 168. PLLDiv_Out bits

| Bit | Symbol | Description |
|--------|------------|---|
| 7 to 0 | PLLDiv_Out | PLL output divider factor; Refer to Section 8.8.2 |

Table 169. Setting for the output divider ratio PLLDiv_Out [7:0]

| Value | Division |
|-------|----------|
| 0 | RFU |
| 1 | RFU |
| 2 | RFU |
| 3 | RFU |
| 4 | RFU |

Table 169. Setting for the output divider ratio PLLDiv_Out [7:0]

| Value | Division |
|-------|----------|
| 5 | RFU |
| 6 | RFU |
| 7 | RFU |
| 8 | 8 |
| 9 | 9 |
| 10 | 10 |
| ... | ... |
| 253 | 253 |
| 254 | 254 |

9.14 Low-power card detection configuration registers

The LPCD registers contain the settings for the low-power card detection. The setting for LPCD_IMax (6 bits) is done by the two highest bits (bit 7, bit 6) of the registers LPCD_QMin, LPCD_QMax and LPCD_IMin each.

9.14.1 LPCD_QMin

Table 170. LPCD_QMin register (address 3Fh)

| Bit | 7 | 6 | 5 | 4 | 3 | 2 | 1 | 0 |
|---------------|-------------|-------------|-----------|---|---|---|---|---|
| Symbol | LPCD_IMax.5 | LPCD_IMax.4 | LPCD_QMin | | | | | |
| Access rights | r/w | r/w | r/w | | | | | |

Table 171. LPCD_QMin bits

| Bit | Symbol | Description |
|--------|-----------|--|
| 7, 6 | LPCD_IMax | Defines the highest two bits of the higher border for the LPCD. If the measurement value of the I channel is higher than LPCD_IMax, a LPCD interrupt request is indicated by bit IRQ0.LPCDIrq. |
| 5 to 0 | LPCD_QMin | Defines the lower border for the LPCD. If the measurement value of the Q channel is higher than LPCD_QMin, a LPCD interrupt request is indicated by bit IRQ0.LPCDIrq. |

9.14.2 LPCD_QMax

Table 172. LPCD_QMax register (address 40h)

| Bit | 7 | 6 | 5 | 4 | 3 | 2 | 1 | 0 |
|---------------|-------------|-------------|-----------|---|---|---|---|---|
| Symbol | LPCD_IMax.3 | LPCD_IMax.2 | LPCD_QMax | | | | | |
| Access rights | r/w | r/w | r/w | | | | | |

Table 173. LPCD_QMax bits

| Bit | Symbol | Description |
|--------|-------------|--|
| 7 | LPCD_IMax.3 | Defines the bit 3 of the high border for the LPCD. If the measurement value of the I channel is higher than LPCD IMax, a LPCD IRQ is raised. |
| 6 | LPCD_IMax.2 | Defines the bit 2 of the high border for the LPCD. If the measurement value of the I channel is higher than LPCD IMax, a LPCD IRQ is raised. |
| 5 to 0 | LPCD_QMax | Defines the high border for the LPCD. If the measurement value of the Q channel is higher than LPCD QMax, a LPCD IRQ is raised. |

9.14.3 LPCD_I Min

Table 174. LPCD_I Min register (address 41h)

| Bit | 7 | 6 | 5 | 4 | 3 | 2 | 1 | 0 |
|---------------|-------------|-------------|------------|---|---|---|---|-----|
| Symbol | LPCD_IMax.1 | LPCD_IMax.0 | LPCD_I Min | | | | | |
| Access rights | r/w | r/w | | | | | | r/w |

Table 175. LPCD_I Min bits

| Bit | Symbol | Description |
|--------|------------|---|
| 7 to 6 | LPCD_IMax | Defines lowest two bits of the higher border for the low-power card detection (LPCD). If the measurement value of the I channel is higher than LPCD IMax, a LPCD IRQ is raised. |
| 5 to 0 | LPCD_I Min | Defines the lower border for the low power card detection. If the measurement value of the I channel is lower than LPCD I Min, a LPCD IRQ is raised. |

9.14.4 LPCD_Result_I

Table 176. LPCD_Result_I register (address 42h)

| Bit | 7 | 6 | 5 | 4 | 3 | 2 | 1 | 0 |
|---------------|------|------|---------------|---|---|---|---|---|
| Symbol | RFU- | RFU- | LPCD_Result_I | | | | | |
| Access rights | - | - | r | | | | | |

Table 177. LPCD_I_Result bits

| Bit | Symbol | Description |
|--------|---------------|--|
| 7 to 6 | RFU | - |
| 5 to 0 | LPCD_Result_I | Shows the result of the last low-power card detection (I-Channel). |

9.14.5 LPCD_Result_Q

Table 178. LPCD_Result_Q register (address 43h)

| Bit | 7 | 6 | 5 | 4 | 3 | 2 | 1 | 0 |
|---------------|-----|--------------|---------------|---|---|---|---|---|
| Symbol | RFU | LPCD_Irq_Clr | LPCD_Result_Q | | | | | |
| Access rights | | r/w | r | | | | | |

Table 179. LPCD_Q_Result bits

| Bit | Symbol | Description |
|--------|---------------|---|
| 7 | RFU | - |
| 6 | LPCD_Irq_Clr | If set no LPCD IRQ is raised any more until the next low-power card detection procedure. Can be used by software to clear the interrupt source. |
| 5 to 0 | LPCD_Result_Q | Shows the result of the last ow power card detection (Q-Channel). |

9.15 Pin configuration

9.15.1 PinEn

Table 180. PinEn register (address 44h)

| Bit | 7 | 6 | 5 | 4 | 3 | 2 | 1 | 0 |
|---------------|----------|-----------|-----------|-----------|--------|--------|--------|---------|
| Symbol | SIGIN_EN | CLKOUT_EN | IFSEL1_EN | IFSEL0_EN | TCK_EN | TMS_EN | TDI_EN | TMDO_EN |
| Access rights | r/w | r/w | r/w | r/w | r/w | r/w | r/w | r/w |

Table 181. PinEn bits

| Bit | Symbol | Description |
|-----|-----------|---|
| 7 | SIGIN_EN | Enables the output functionality on SIGIN (pin 5). The pin is then used as I/O. |
| 6 | CLKOUT_EN | Enables the output functionality of the CLKOUT (pin 22). The pin is then used as I/O. The CLKOUT function is switched off. |
| 5 | IFSEL1_EN | Enables the output functionality of the IFSEL1 (pin 27). The pin is then used as I/O. |
| 4 | IFSEL0_EN | Enables the output functionality of the IFSEL0 (pin 26). The pin is then used as I/O. |
| 3 | TCK_EN | Enables the output functionality of the TCK (pin 4) of the boundary scan interface. The pin is then used as I/O. If the boundary scan is activated in EEPROM, this bit has no function. |
| 2 | TMS_EN | Enables the output functionality of the TMS (pin 2) of the boundary scan interface. The pin is then used as I/O. If the boundary scan is activated in EEPROM, this bit has no function. |
| 1 | TDI_EN | Enables the output functionality of the TDI (pin 1) of the boundary scan interface. The pin is then used as I/O. If the boundary scan is activated in EEPROM, this bit has no function. |
| 0 | TDO_EN | Enables the output functionality of the TDO (pin 3) of the boundary scan interface. The pin is then used as I/O. If the boundary scan is activated in EEPROM, this bit has no function. |

9.15.2 PinOut

Table 182. PinOut register (address 45h)

| Bit | 7 | 6 | 5 | 4 | 3 | 2 | 1 | 0 |
|---------------|-----------|------------|------------|------------|---------|---------|---------|---------|
| Symbol | SIGIN_OUT | CLKOUT_OUT | IFSEL1_OUT | IFSEL0_OUT | TCK_OUT | TMS_OUT | TDI_OUT | TDO_OUT |
| Access rights | r/w | r/w | r/w | r/w | r/w | r/w | r/w | r/w |

Table 183. PinOut bits

| Bit | Symbol | Description |
|-----|------------|---------------------------------|
| 7 | SIGIN_OUT | Output buffer of the SIGIN pin |
| 6 | CLKOUT_OUT | Output buffer of the CLKOUT pin |
| 5 | IFSEL1_OUT | Output buffer of the IFSEL1 pin |
| 4 | IFSEL0_OUT | Output buffer of the IFSEL0 pin |
| 3 | TCK_OUT | Output buffer of the TCK pin |
| 2 | TMS_OUT | Output buffer of the TMS pin |
| 1 | TDI_OUT | Output buffer of the TDI pin |
| 0 | TDO_OUT | Output buffer of the TDO pin |

9.15.3 PinIn

Table 184. PinIn register (address 46h)

| Bit | 7 | 6 | 5 | 4 | 3 | 2 | 1 | 0 |
|---------------|----------|-----------|-----------|-----------|--------|--------|--------|--------|
| Symbol | SIGIN_IN | CLKOUT_IN | IFSEL1_IN | IFSEL0_IN | TCK_IN | TMS_IN | TDI_IN | TDO_IN |
| Access rights | r | r | r | r | r | r | r | r |

Table 185. PinIn bits

| Bit | Symbol | Description |
|-----|-----------|--------------------------------|
| 7 | SIGIN_IN | Input buffer of the SIGIN pin |
| 6 | CLKOUT_IN | Input buffer of the CLKOUT pin |
| 5 | IFSEL1_IN | Input buffer of the IFSEL1 pin |
| 4 | IFSEL0_IN | Input buffer of the IFSEL0 pin |
| 3 | TCK_IN | Input buffer of the TCK pin |
| 2 | TMS_IN | Input buffer of the TMS pin |
| 1 | TDI_IN | Input buffer of the TDI pin |
| 0 | TDO_IN | Input buffer of the TDO pin |

9.15.4 SigOut

Table 186. SigOut register (address 47h)

| Bit | 7 | 6 | 5 | 4 | 3 | 2 | 1 | 0 |
|---------------|-----------|-----|---|---|-----------|---|---|---|
| Symbol | Pad Speed | RFU | | | SigOutSel | | | |
| Access rights | r/w | - | | | r/w | | | |

Table 187. SigOut bits

| Bit | Symbol | Description |
|--------|-----------|--|
| 7 | PadSpeed | If set, the I/O pins are supporting a fast switching mode. The fast mode for the I/O's will increase the peak current consumption of the device, especially if multiple I/Os are switching at the same time. The power supply needs to be designed to deliver this peak currents. |
| 6 to 4 | RFU | - |
| 3 to 0 | SIGOutSel | 0h, 1h - The pin SIGOUT is 3-state 2h - The pin SIGOUT is 0 3h - The pin SIGOUT is 1 4h - The pin SIGOUT shows the TX-envelope 5h - The pin SIGOUT shows the TX-active signal 6h - The pin SIGOUT shows the S3C (generic) signal 7h - The pin SIGOUT shows the RX-envelope (only valid for ISO/IEC 14443A, 106 kBd) 8h - The pin SIGOUT shows the RX-active signal 9h - The pin SIGOUT shows the RX-bit signal |

9.16 Version register

9.16.1 Version

Table 188. Version register (address 7Fh)

| Bit | 7 | 6 | 5 | 4 | 3 | 2 | 1 | 0 |
|---------------|---------|---|---|---|------------|---|---|---|
| Symbol | Version | | | | SubVersion | | | |
| Access rights | r | | | | r | | | |

Table 189. Version bits

| Bit | Symbol | Description |
|--------|------------|---|
| 7 to 4 | Version | Includes the version of the SLRC610 silicon. |
| 3 to 0 | SubVersion | Includes the subversion of the SLRC610 silicon. |

10. Limiting values

Table 190. Limiting values
In accordance with the Absolute Maximum Rating System (IEC 60134).

| Symbol | Parameter | Conditions | Min | Max | Unit |
|-----------------------|---------------------------------|---|------|------|------|
| V _{DD} | supply voltage | | -0.5 | +5.5 | V |
| V _{DD(PVDD)} | PVDD supply voltage | | -0.5 | +5.5 | V |
| V _{DD(TVDD)} | TVDD supply voltage | | -0.5 | +5.5 | V |
| V _{i(RXP)} | input voltage on pin RXP | | -0.5 | +2.0 | V |
| V _{i(RXN)} | input voltage on pin RXN | | -0.5 | +2.0 | V |
| P _{tot} | total power dissipation | per package | - | 1125 | mW |
| V _{ESD(HBM)} | electrostatic discharge voltage | Human Body Model (HBM); 1500 Ω, 100 pF; JESD22-A114-B | - | 2000 | V |
| V _{ESD(CDM)} | electrostatic discharge voltage | Charge Device Model (CDM); | - | 500 | V |
| T _{j(max)} | maximum junction temperature | | - | 150 | °C |

11. Recommended operating conditions

Table 191. Operating conditions

| Symbol | Parameter | Conditions | Min | Typ | Max | Unit |
|-----------------------|---------------------|------------|-------|-----|-----|------|
| V _{DD} | supply voltage | | 3 | 5 | 5.5 | V |
| V _{DD(TVDD)} | TVDD supply voltage | | [1] 3 | 5 | 5.5 | V |
| V _{DD(PVDD)} | PVDD supply voltage | | 3 | 5 | 5.5 | V |
| T _{amb} | ambient temperature | | -25 | - | +85 | °C |

[1] V_{DD(PVDD)} must always be the same or lower than V_{DD}.

12. Thermal characteristics

Table 192. Thermal characteristics

| Symbol | Parameter | Conditions | Package | Typ | Unit |
|----------------------|---|---|---------|-----|------|
| R _{th(j-a)} | thermal resistance from junction to ambient | in still air with exposed pin soldered on a 4 layer JEDEC PCB | HVQFN32 | 40 | K/W |

13. Characteristics

Table 193. Characteristics

| Symbol | Parameter | Conditions | Min | Typ | Max | Unit |
|--|--------------------------|------------------------|--------------------------|-----|-----------------------------|------|
| Input characteristics I/O Pin Characteristics IF3-SDA in I²C configuration | | | | | | |
| I _{LI} | input leakage current | output disabled | - | 2 | 100 | nA |
| V _{IL} | LOW-level input voltage | | -0.5 | - | +0.3V _{DD(PVDD)} | V |
| V _{IH} | HIGH-level input voltage | | 0.7V _{DD(PVDD)} | - | V _{DD(PVDD)} + 0.5 | V |
| V _{OL} | LOW-level output voltage | I _{OL} = 3 mA | - | - | 0.3 | V |

Table 193. Characteristics ...continued

| Symbol | Parameter | Conditions | Min | Typ | Max | Unit |
|-------------------|---|---|---------------------|-----|-----|-------|
| I _{OL} | LOW-level output current | V _{OL} = 0.4 V; Standard mode, Fast mode | 4 | - | - | mA |
| | | V _{OL} = 0.6 V; Standard mode, Fast mode | 6 | - | - | mA |
| t _{f(o)} | output fall time | Standard mode, Fast mode, C _L < 400 pF | - | - | 250 | ns |
| | | Fast mode +; C _L < 550 pF | - | - | 120 | ns |
| t _{SP} | pulse width of spikes that must be suppressed by the input filter | | 0 | - | 50 | ns |
| C _i | input capacitance | | - | 3.5 | 5 | pF |
| C _L | load capacitance | Standard mode | - | - | 400 | pF |
| | | Fast mode | - | - | 550 | pF |
| t _{EEER} | EEPROM data retention time | T _{amb} = +55 °C | 10 | - | - | year |
| N _{EEEC} | EEPROM endurance (number of programming cycles) | under all operating conditions | 5 x 10 ⁵ | - | - | cycle |

Analog and digital supply AVDD, DVDD

| | | | | | | |
|------------------|------------------------|------|-----|-----|---|----|
| V _{DDA} | analog supply voltage | | - | 1.8 | - | V |
| V _{DDD} | digital supply voltage | | - | 1.8 | - | V |
| C _L | load capacitance | AVDD | 220 | 470 | - | nF |
| C _L | load capacitance | DVDD | 220 | 470 | - | nF |

Current consumption

| | | | | | | |
|-----------------------|---------------------|-----------------|---|------|-----|----|
| I _{stb} | standby current | Standby bit = 1 | - | 3 | 6 | μA |
| I _{DD} | supply current | modem on | - | 17 | 20 | mA |
| | | modem off | - | 0.45 | 0.5 | mA |
| I _{DD(TVDD)} | TVDD supply current | | - | 100 | 200 | mA |

I/O pin characteristics SIGIN, SIGOUT, CLKOUT, IFSEL0, IFSEL1, TCK, TMS, TDI, TDO, IRQ, IF0, IF1, IF2, SCL2, SDA2

| | | | | | | |
|-----------------|---------------------------|---|--------------------------|-----|-----------------------------|----|
| I _{LI} | input leakage current | output disabled | - | 50 | 500 | nA |
| V _{IL} | LOW-level input voltage | | -0.5 | - | 0.3V _{DD(PVDD)} | V |
| V _{IH} | HIGH-level input voltage | | 0.7V _{DD(PVDD)} | - | V _{DD(PVDD)} + 0.5 | V |
| V _{OL} | LOW-level output voltage | I _{OL} = 4 mA, V _{DD(PVDD)} = 5.0 V | - | - | 0.4 | V |
| | | I _{OL} = 4 mA, V _{DD(PVDD)} = 3.3 V | - | - | 0.4 | V |
| V _{OH} | HIGH-level output voltage | I _{OL} = 4 mA, V _{DD(PVDD)} = 5.0 V | 4.6 | - | - | V |
| | | I _{OL} = 4 mA, V _{DD(PVDD)} = 3.3 V | 2.9 | - | - | V |
| C _i | input capacitance | | - | 2.5 | 4.5 | pF |

Pull-up resistance for TCK, TMS, TDI, IF2

| | | | | | | |
|-----------------|--------------------|--|----|----|-----|----|
| R _{pu} | pull-up resistance | | 50 | 72 | 120 | KΩ |
|-----------------|--------------------|--|----|----|-----|----|

Table 193. Characteristics ...continued

| Symbol | Parameter | Conditions | Min | Typ | Max | Unit |
|---|------------------------------|---|-----------------------|-------|-----------------------|------|
| Pin characteristics AUX 1, AUX 2 | | | | | | |
| V _o | output voltage | | 0 | - | 1.8 | V |
| C _L | load capacitance | | - | - | 400 | pF |
| Pin characteristics RXP, RXN | | | | | | |
| V _i | input voltage | | 0 | - | 1.8 | V |
| C _i | input capacitance | | 2 | 3.5 | 5 | pF |
| V _{mod(pp)} | modulation voltage | $V_{mod(pp)} = V_{i(pp)(max)} - V_{i(pp)(min)}$ | - | 2.5 | - | mV |
| V _{pp} | signal on RXP, RXN | | - | - | 1.65 | V |
| Pins TX1 and TX2 | | | | | | |
| V _o | output voltage | | V _{ss(TVSS)} | - | V _{DD(TVDD)} | V |
| R _o | output resistance | | - | 1.5 | - | Ω |
| Current consumption | | | | | | |
| I _{pd} | power-down current | ambient temp = 25°C | - | 8 | 40 | nA |
| | | ambient temp = 85°C | - | 200 | 400 | nA |
| I _{stby} | standby current | ambient temp = 25°C | [1] | 3 | 6 | μA |
| I _{LPCD} | LPCD sleep current | | [1] | 3 | 6 | μA |
| I _{DD} | supply current | | - | 17 | 20 | mA |
| | | modem off; transceiver off | - | 0.45 | 0.5 | mA |
| I _{DD(PVDD)} | PVDD supply current | no load on digital pin | [2] | - | 10 | μA |
| I _{DD(TVDD)} | TVDD supply current | | [3][4][5] | 100 | 200 | mA |
| Clock frequency Pin CLKOUT | | | | | | |
| f _{clk} | clock frequency | configured to 27.12 MHz | - | 27.12 | - | MHz |
| δ _{clk} | clock duty cycle | | - | 50 | - | % |
| Crystal oscillator | | | | | | |
| V _{o(p-p)} | peak-to-peak output voltage | pin XTAL1 | - | 1 | - | V |
| V _i | input voltage | pin XTAL1 | 0 | - | 1.8 | V |
| C _i | input capacitance | pin XTAL1 | - | 3 | - | pF |
| Typical input requirements | | | | | | |
| f _{xtal} | crystal frequency | | - | 27.12 | - | MHz |
| ESR | equivalent series resistance | | - | 50 | 100 | Ω |
| C _L | load capacitance | | - | 10 | - | pF |
| P _{xtal} | crystal power dissipation | | - | 50 | 100 | μW |

[1] I_{pd} is the total current for all supplies.

[2] I_{DD(PVDD)} depends on the overall load at the digital pins.

[3] I_{DD(TVDD)} depends on V_{DD(TVDD)} and the external circuit connected to pins TX1 and TX2.

[4] During typical circuit operation, the overall current is below 100 mA.

[5] Typical value using a complementary driver configuration and an antenna matched to 40 Ω between pins TX1 and TX2 at 13.56 MHz.

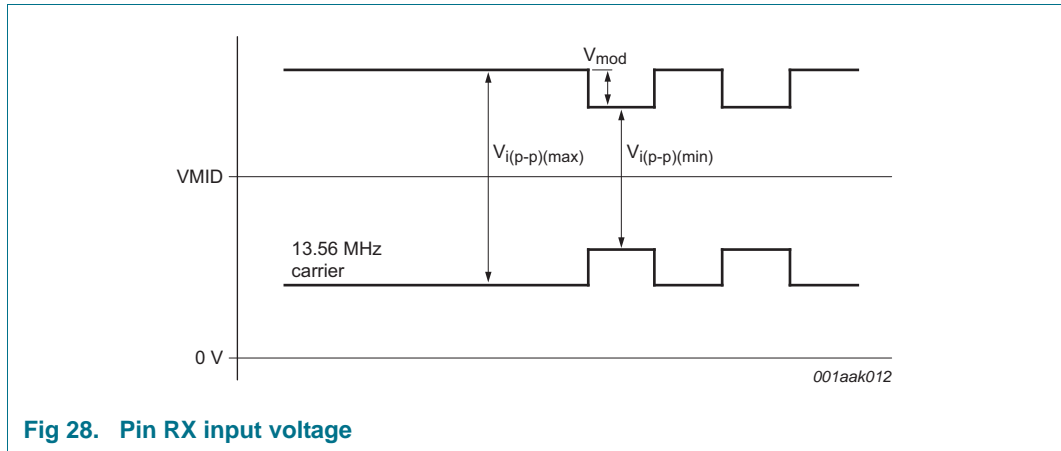

Fig 28. Pin RX input voltage

13.1 Timing characteristics

Table 194. SPI timing characteristics

| Symbol | Parameter | Conditions | Min | Typ | Max | Unit |
|-------------------|------------------------------------|----------------------|-----|-----|-----|------|
| t_{SCKL} | SCK LOW time | | 50 | - | - | ns |
| t_{SCKH} | SCK HIGH time | | 50 | - | - | ns |
| $t_{h(SCKH-D)}$ | SCK HIGH to data input hold time | SCK to changing MOSI | 25 | - | - | ns |
| $t_{su(D-SCKH)}$ | data input to SCK HIGH set-up time | changing MOSI to SCK | 25 | - | - | ns |
| $t_{h(SCKL-Q)}$ | SCK LOW to data output hold time | SCK to changing MISO | - | - | 25 | ns |
| $t_{(SCKL-NSSH)}$ | SCK LOW to NSS HIGH time | | 0 | - | - | ns |
| t_{NSSH} | NSS HIGH time | before communication | 50 | - | - | ns |

Remark: To send more bytes in one data stream the NSS signal must be LOW during the send process. To send more than one data stream the NSS signal must be HIGH between each data stream.

Table 195. I²C-bus timing in fast mode and fast mode plus

| Symbol | Parameter | Conditions | Fast mode | | Fast mode Plus | | Unit |
|--------------|--|---|-----------|-----|----------------|------|------|
| | | | Min | Max | Min | Max | |
| f_{SCL} | SCL clock frequency | | 0 | 400 | 0 | 1000 | kHz |
| $t_{HD;STA}$ | hold time (repeated) START condition | after this period, the first clock pulse is generated | 600 | - | 260 | - | ns |
| $t_{SU;STA}$ | set-up time for a repeated START condition | | 600 | - | 260 | - | ns |
| $t_{SU;STO}$ | set-up time for STOP condition | | 600 | - | 260 | - | ns |
| t_{LOW} | LOW period of the SCL clock | | 1300 | - | 500 | - | ns |
| t_{HIGH} | HIGH period of the SCL clock | | 600 | - | 260 | - | ns |
| $t_{HD;DAT}$ | data hold time | | 0 | 900 | - | 450 | ns |

Table 195. I²C-bus timing in fast mode and fast mode plus ...continued

| Symbol | Parameter | Conditions | Fast mode | | Fast mode Plus | | Unit |
|---------------------|--|---------------------|-----------|-----|----------------|-----|------|
| | | | Min | Max | Min | Max | |
| t _{SU;DAT} | data set-up time | | 100 | - | - | - | ns |
| t _r | rise time | SCL signal | 20 | 300 | - | 120 | ns |
| t _f | fall time | SCL signal | 20 | 300 | - | 120 | ns |
| t _r | rise time | SDA and SCL signals | 20 | 300 | - | 120 | ns |
| t _f | fall time | SDA and SCL signals | 20 | 300 | - | 120 | ns |
| t _{BUF} | bus free time between a STOP and START condition | | 1.3 | - | 0.5 | - | µs |

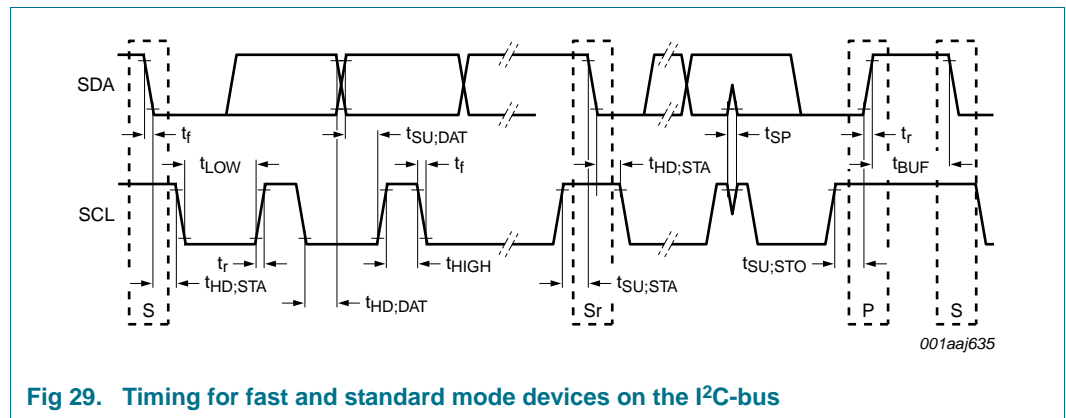

Fig 29. Timing for fast and standard mode devices on the I²C-bus

14. Application information

A typical application diagram using a complementary antenna connection to the SLRC610 is shown in [Figure 30](#).

The antenna tuning and RF part matching is described in the application note [Ref. 1](#) and [Ref. 2](#).

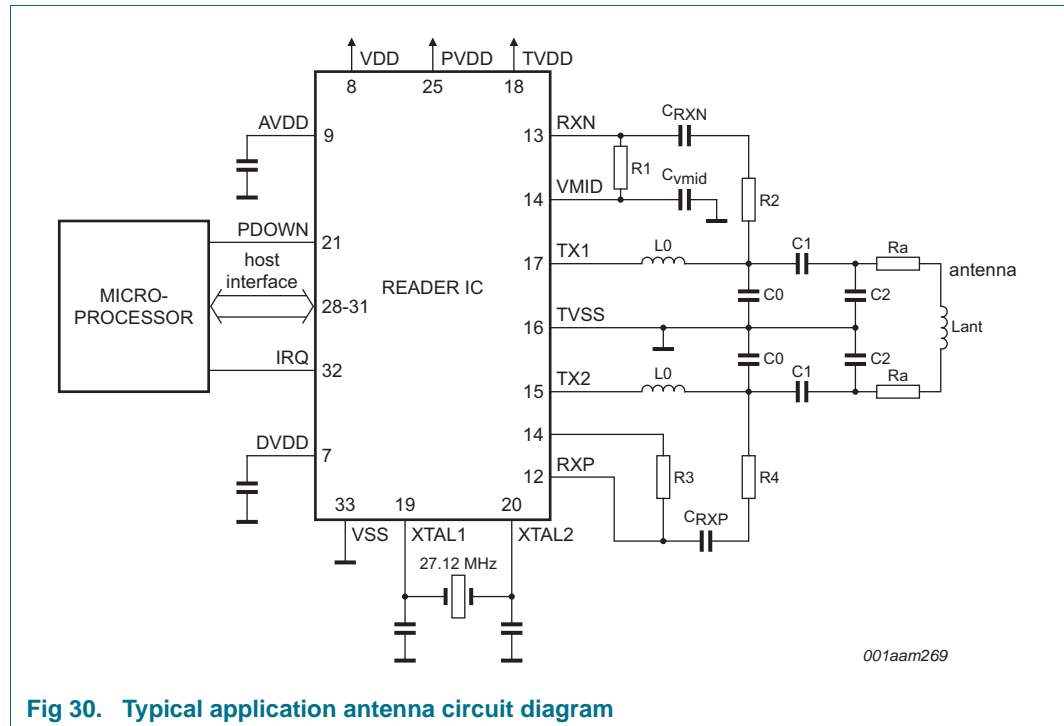

Fig 30. Typical application antenna circuit diagram

14.1 Antenna design description

The matching circuit for the antenna consists of an EMC low pass filter (L0 and C0), a matching circuitry (C1 and C2), and a receiving circuits (R1 = R3, R2 = R4, C3 = C5 and C4 = C6;), and the antenna itself. The receiving circuit component values needs to be designed for operation with the SLRC610. A reuse of dedicated antenna designs done for other products without adaptation of component values will result in degraded performance.

For a more detailed information about designing and tuning the antenna, please refer to the relevant application notes:

- MICORE reader IC family; Directly Matched Antenna Design, [Ref. 1](#) and
- MIFARE (14443A) 13.56 MHz RFID Proximity Antennas, [Ref. 2](#).

14.1.1 EMC low pass filter

The MIFARE system operates at a frequency of 13.56 MHz. This frequency is derived from a quartz oscillator to clock the SLRC610 and is also the basis for driving the antenna with the 13.56 MHz energy carrier. This will not only cause emitted power at 13.56 MHz

but will also emit power at higher harmonics. The international EMC regulations define the amplitude of the emitted power in a broad frequency range. Thus, an appropriate filtering of the output signal is necessary to fulfil these regulations.

Remark: The PCB layout has a major influence on the overall performance of the filter.

14.1.2 Antenna matching

Due to the impedance transformation of the given low pass filter, the antenna coil has to be matched to a certain impedance. The matching elements C1 and C2 can be estimated and have to be fine tuned depending on the design of the antenna coil.

The correct impedance matching is important to provide the optimum performance. The overall quality factor has to be considered to guarantee a proper ISO/IEC 14443 communication scheme. Environmental influences have to be considered as well as common EMC design rules.

For details refer to the NXP application notes.

14.1.3 Receiving circuit

The internal receiving concept of the SLRC610 makes use both side-bands of the sub-carrier load modulation of the card response via a differential receiving concept (RXP, RXN). No external filtering is required.

It is recommended to use the internally generated VMID potential as the input potential of pin RX. This DC voltage level of VMID has to be coupled to the Rx-pins via R2 and R4. To provide a stable DC reference voltage capacitances C4, C6 has to be connected between VMID and ground. Refer to [Figure 30](#)

Considering the (AC) voltage limits at the Rx-pins the AC voltage divider of R1 + C3 and R2 as well as R3 + C5 and R4 has to be designed. Depending on the antenna coil design and the impedance matching the voltage at the antenna coil varies from antenna design to antenna design. Therefore the recommended way to design the receiving circuit is to use the given values for R1(= R3), R2 (= R4), and C3 (= C5) from the above mentioned application note, and adjust the voltage at the RX-pins by varying R1(= R3) within the given limits.

Remark: R2 and R4 are AC-wise connected to ground (via C4 and C6).

14.1.4 Antenna coil

The precise calculation of the antenna coils' inductance is not practicable but the inductance can be **estimated** using the following formula. We recommend designing an antenna either with a circular or rectangular shape.

$$L_1 = 2 \cdot I_1 \cdot \left(\ln \left\langle \frac{I_1}{D_1} \right\rangle - K \right) N_1^{1,8} \quad (4)$$

- I_1 - Length in cm of one turn of the conductor loop
- D_1 - Diameter of the wire or width of the PCB conductor respectively
- K - Antenna shape factor ($K = 1,07$ for circular antennas and $K = 1,47$ for square antennas)
- L_1 - Inductance in nH
- N_1 - Number of turns
- \ln : Natural logarithm function

The actual values of the **antenna inductance, resistance, and capacitance at 13.56 MHz** depend on various parameters such as:

- antenna construction (Type of PCB)
- thickness of conductor
- distance between the windings
- shielding layer
- metal or ferrite in the near environment

Therefore a measurement of those parameters under real life conditions, or at least a rough measurement and a tuning procedure is highly recommended to guarantee a reasonable performance. For details refer to the above mentioned application notes.

15. Package outline

HVQFN32: plastic thermal enhanced very thin quad flat package; no leads; 32 terminals; body 5 x 5 x 0.85 mm

SOT617-1

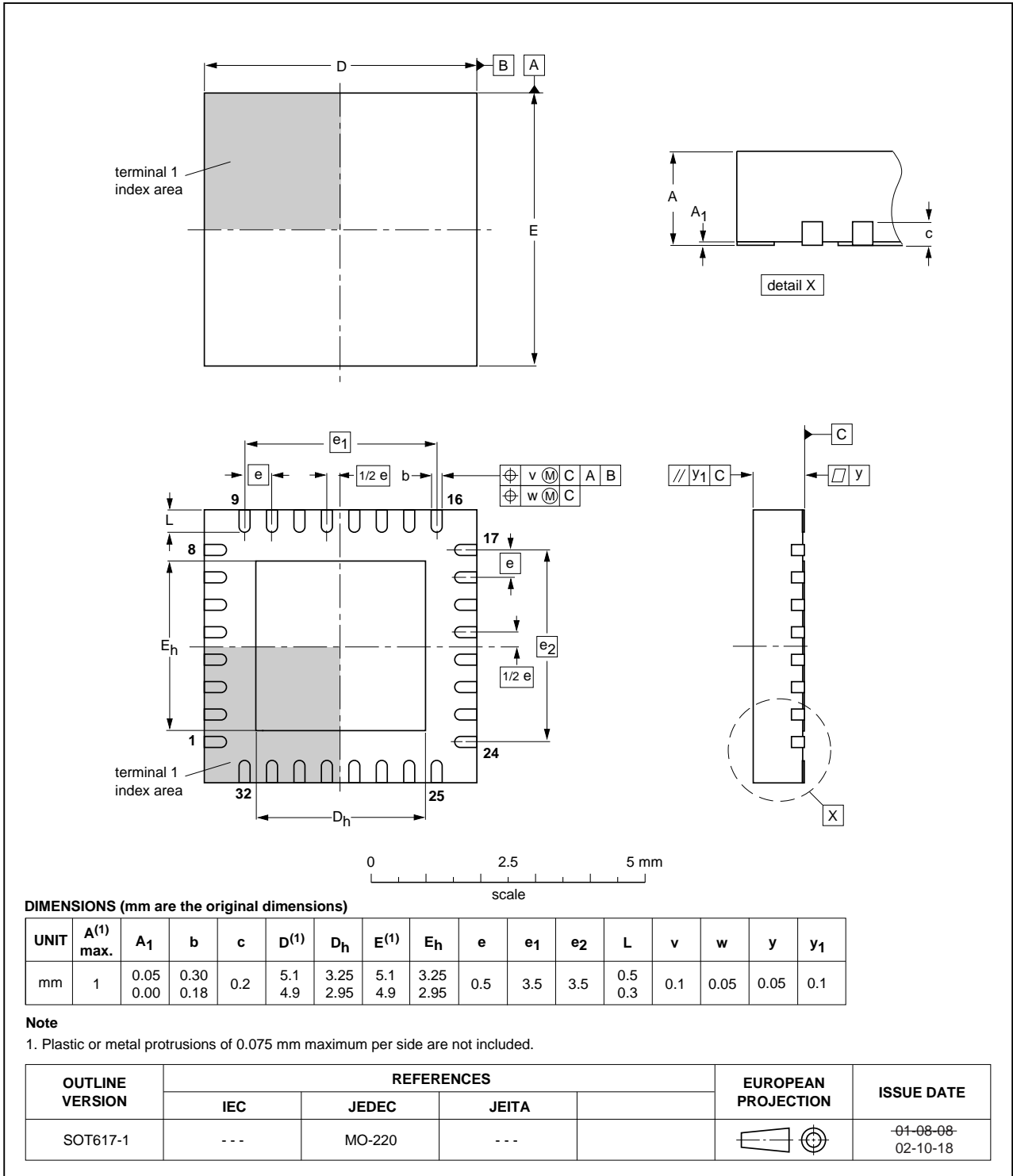

Fig 31. Package outline SOT617-1 (HVQFN32)

Detailed package information can be found at <http://www.nxp.com/package/SOT617-1.html>.

16. Handling information

Moisture Sensitivity Level (MSL) evaluation has been performed according to *SNW-FQ-225B rev.04/07/07 (JEDEC J-STD-020C)*. MSL for this package is level 2 which means 260 °C convection reflow temperature.

For MSL2:

- Dry pack is required.
- 1 year out-of-pack floor life at maximum ambient temperature 30 °C/ 85 % RH.

For MSL1:

- No dry pack is required.
- No out-of-pack floor live spec. required.

17. Packing information

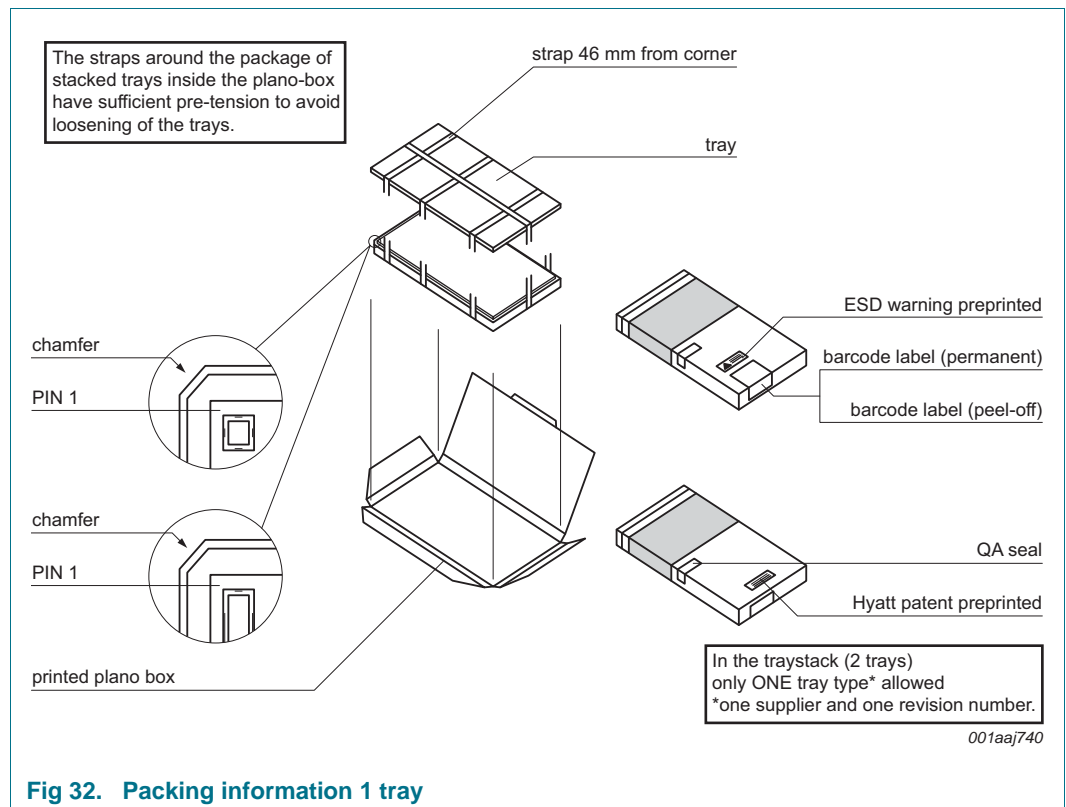

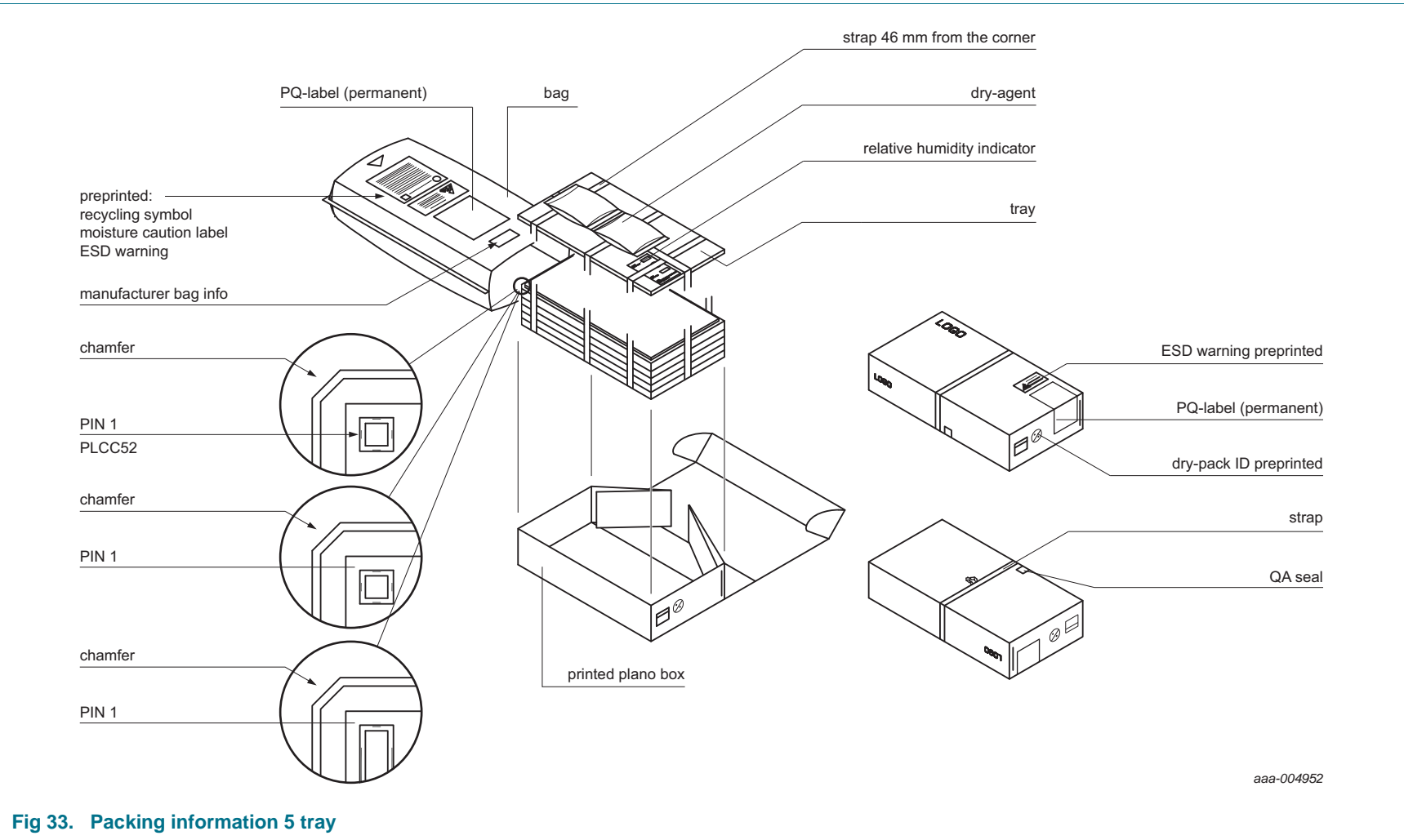

Fig 33. Packing information 5 tray

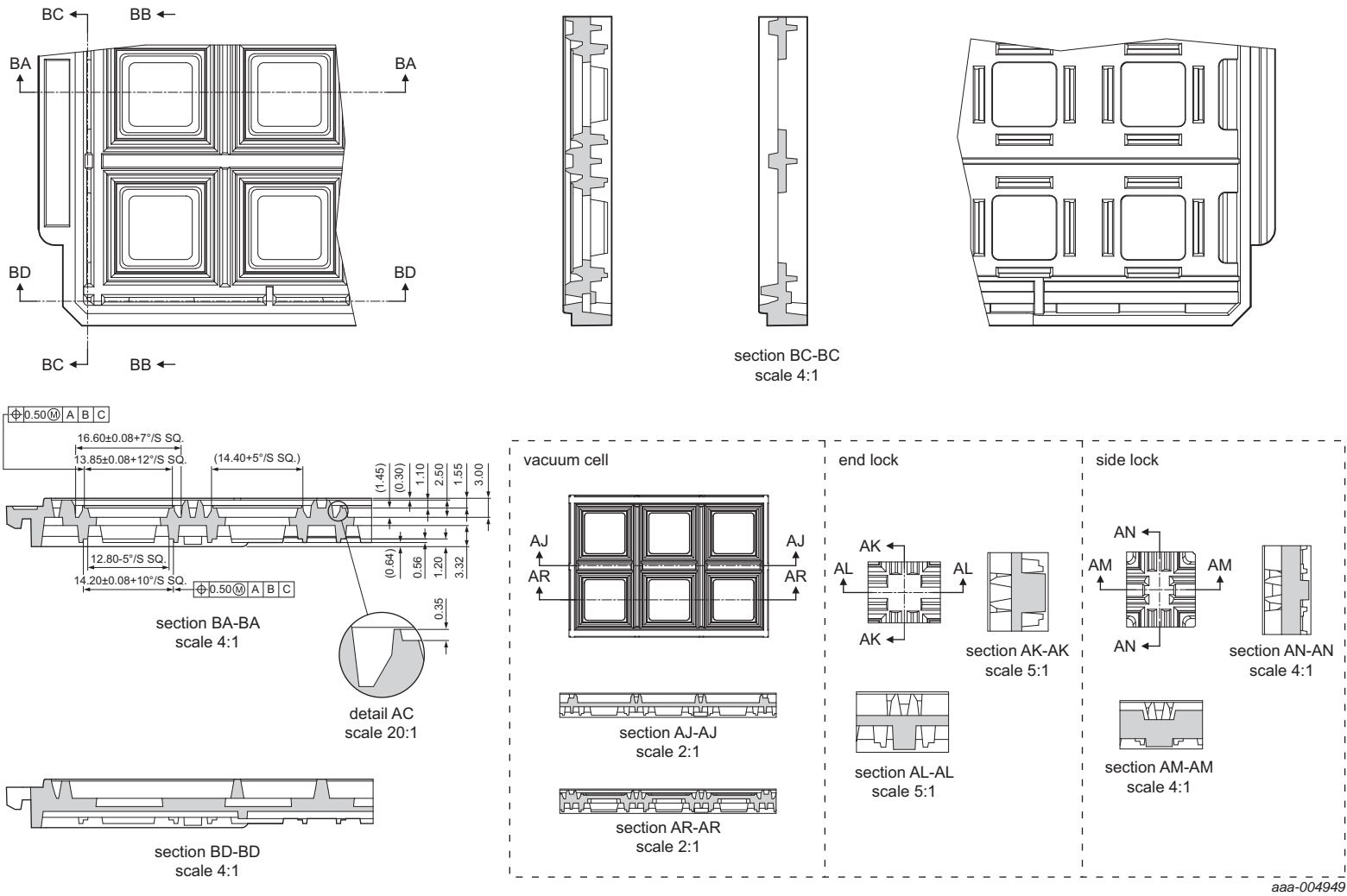

Fig 34. Tray details

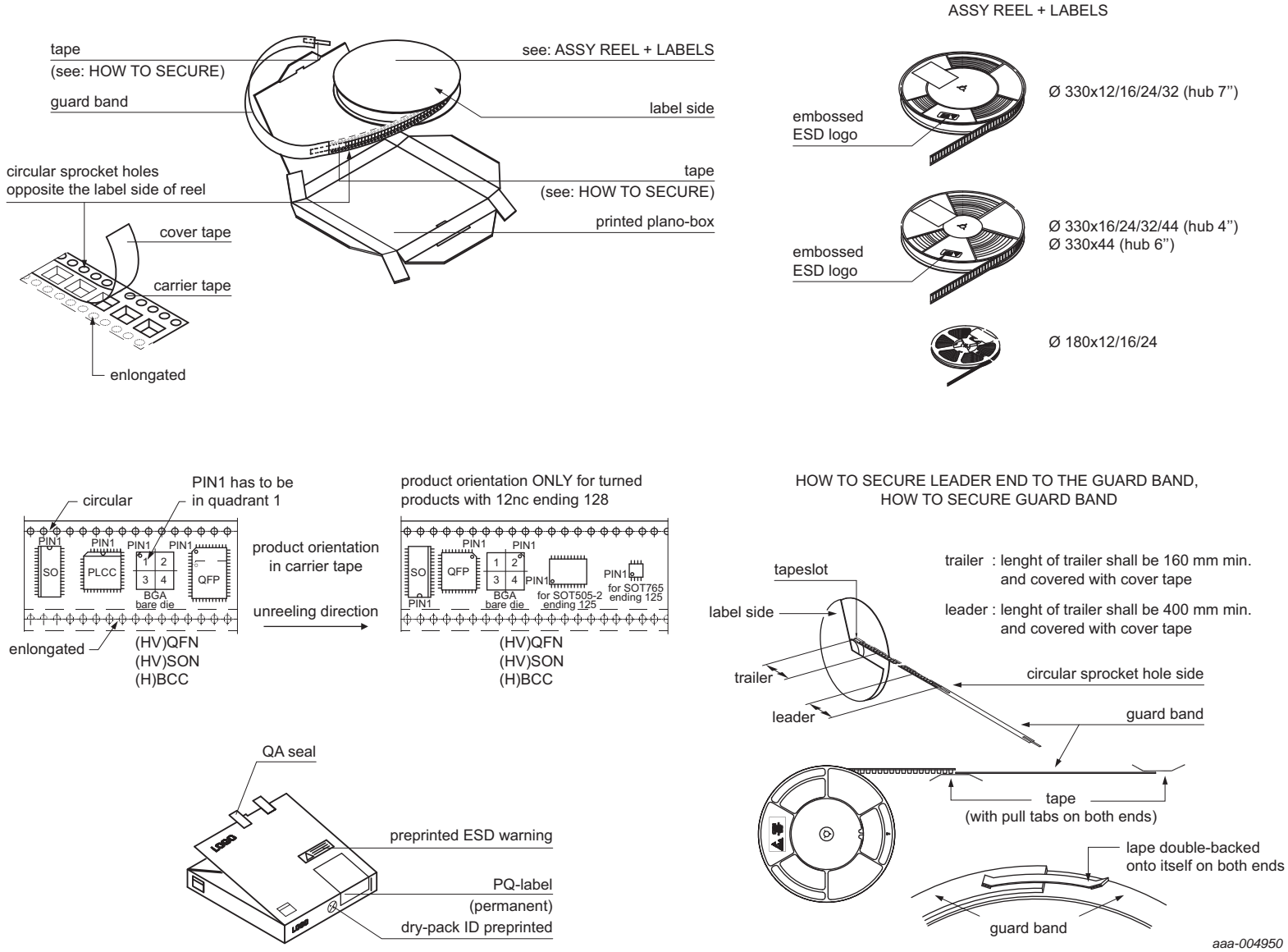

Fig 35. Packing information Reel

18. Abbreviations

Table 196. Abbreviations

| Acronym | Description |
|------------------|---|
| ADC | Analog-to-Digital Converter |
| BPSK | Binary Phase Shift Keying |
| CRC | Cyclic Redundancy Check |
| CW | Continuous Wave |
| EGT | Extra Guard Time |
| EMC | Electro Magnetic Compatibility |
| EMD | Electro Magnetic Disturbance |
| EOF | End Of Frame |
| EPC | Electronic Product Code |
| ETU | Elementary Time Unit |
| GPIO | General Purpose Input/Output |
| HBM | Human Body Model |
| I ² C | Inter-Integrated Circuit |
| LFO | Low Frequency Oscillator |
| LPCD | Low-Power Card Detection |
| LSB | Least Significant Bit |
| MISO | Master In Slave Out |
| MOSI | Master Out Slave In |
| MSB | Most Significant Bit |
| NRZ | Not Return to Zero |
| NSS | Not Slave Select |
| PCD | Proximity Coupling Device |
| PLL | Phase-Locked Loop |
| RZ | Return To Zero |
| RX | Receiver |
| SAM | Secure Access Module |
| SOF | Start Of Frame |
| SPI | Serial Peripheral Interface |
| SW | Software |
| TTimer | Timing of the clk period |
| TX | Transmitter |
| UART | Universal Asynchronous Receiver Transmitter |
| UID | Unique IDentification |
| VCO | Voltage Controlled Oscillator |

19. References

- [1] **Application note** — *MFRC52x Reader IC Family Directly Matched Antenna Design*
- [2] **Application note** — *MIFARE (ISO/IEC 14443 A) 13.56 MHz RFID Proximity Antennas*
- [3] **BSDL File** — *Boundary scan description language file of the SLRC610*

20. Revision history

Table 197. Revision history

| Document ID | Release date | Data sheet status | Change notice | Supersedes |
|----------------|---|--------------------|---------------|---------------|
| SLRC610 v.3.4 | 20140206 | Product data sheet | - | SLRC610 v.3.3 |
| Modifications: | <ul style="list-style-type: none"> • Typo corrected | | | |
| SLRC610 v.3.3 | 20140204 | Product data sheet | - | SLRC610 v.3.2 |
| Modifications: | <ul style="list-style-type: none"> • PVDD, TVDD data updated • Information on FIFO size corrected • Typing error corrected in description for LPCD • WaterLevel and FIFOLength updated in register overview description • WaterLevel and FIFOLength updated in register FIFOControl • Waterlevel Register updated • FIFOLength Register updated • Section 9.15.2 "PinOut": Pin Out register description corrected | | | |
| SLRC610 v.3.2 | 20130910 | Product data sheet | - | SLRC610 v.3.1 |
| Modifications: | <ul style="list-style-type: none"> • Update of EEPROM content • Descriptive title changed • Table 182 "PinOut register (address 45h)": corrected | | | |
| SLRC610 v.3.1 | 20120906 | Product data sheet | - | - |

21. Legal information

21.1 Data sheet status

| Document status ^{[1][2]} | Product status ^[3] | Definition |
|-----------------------------------|-------------------------------|---|
| Objective [short] data sheet | Development | This document contains data from the objective specification for product development. |
| Preliminary [short] data sheet | Qualification | This document contains data from the preliminary specification. |
| Product [short] data sheet | Production | This document contains the product specification. |

[1] Please consult the most recently issued document before initiating or completing a design.

[2] The term 'short data sheet' is explained in section "Definitions".

[3] The product status of device(s) described in this document may have changed since this document was published and may differ in case of multiple devices. The latest product status information is available on the Internet at URL <http://www.nxp.com>.

21.2 Definitions

Draft — The document is a draft version only. The content is still under internal review and subject to formal approval, which may result in modifications or additions. NXP Semiconductors does not give any representations or warranties as to the accuracy or completeness of information included herein and shall have no liability for the consequences of use of such information.

Short data sheet — A short data sheet is an extract from a full data sheet with the same product type number(s) and title. A short data sheet is intended for quick reference only and should not be relied upon to contain detailed and full information. For detailed and full information see the relevant full data sheet, which is available on request via the local NXP Semiconductors sales office. In case of any inconsistency or conflict with the short data sheet, the full data sheet shall prevail.

Product specification — The information and data provided in a Product data sheet shall define the specification of the product as agreed between NXP Semiconductors and its customer, unless NXP Semiconductors and customer have explicitly agreed otherwise in writing. In no event however, shall an agreement be valid in which the NXP Semiconductors product is deemed to offer functions and qualities beyond those described in the Product data sheet.

21.3 Disclaimers

Limited warranty and liability — Information in this document is believed to be accurate and reliable. However, NXP Semiconductors does not give any representations or warranties, expressed or implied, as to the accuracy or completeness of such information and shall have no liability for the consequences of use of such information. NXP Semiconductors takes no responsibility for the content in this document if provided by an information source outside of NXP Semiconductors.

In no event shall NXP Semiconductors be liable for any indirect, incidental, punitive, special or consequential damages (including - without limitation - lost profits, lost savings, business interruption, costs related to the removal or replacement of any products or rework charges) whether or not such damages are based on tort (including negligence), warranty, breach of contract or any other legal theory.

Notwithstanding any damages that customer might incur for any reason whatsoever, NXP Semiconductors' aggregate and cumulative liability towards customer for the products described herein shall be limited in accordance with the *Terms and conditions of commercial sale* of NXP Semiconductors.

Right to make changes — NXP Semiconductors reserves the right to make changes to information published in this document, including without limitation specifications and product descriptions, at any time and without notice. This document supersedes and replaces all information supplied prior to the publication hereof.

Suitability for use — NXP Semiconductors products are not designed, authorized or warranted to be suitable for use in life support, life-critical or safety-critical systems or equipment, nor in applications where failure or malfunction of an NXP Semiconductors product can reasonably be expected to result in personal injury, death or severe property or environmental damage. NXP Semiconductors and its suppliers accept no liability for inclusion and/or use of NXP Semiconductors products in such equipment or applications and therefore such inclusion and/or use is at the customer's own risk.

Applications — Applications that are described herein for any of these products are for illustrative purposes only. NXP Semiconductors makes no representation or warranty that such applications will be suitable for the specified use without further testing or modification.

Customers are responsible for the design and operation of their applications and products using NXP Semiconductors products, and NXP Semiconductors accepts no liability for any assistance with applications or customer product design. It is customer's sole responsibility to determine whether the NXP Semiconductors product is suitable and fit for the customer's applications and products planned, as well as for the planned application and use of customer's third party customer(s). Customers should provide appropriate design and operating safeguards to minimize the risks associated with their applications and products.

NXP Semiconductors does not accept any liability related to any default, damage, costs or problem which is based on any weakness or default in the customer's applications or products, or the application or use by customer's third party customer(s). Customer is responsible for doing all necessary testing for the customer's applications and products using NXP Semiconductors products in order to avoid a default of the applications and the products or of the application or use by customer's third party customer(s). NXP does not accept any liability in this respect.

Limiting values — Stress above one or more limiting values (as defined in the Absolute Maximum Ratings System of IEC 60134) will cause permanent damage to the device. Limiting values are stress ratings only and (proper) operation of the device at these or any other conditions above those given in the Recommended operating conditions section (if present) or the Characteristics sections of this document is not warranted. Constant or repeated exposure to limiting values will permanently and irreversibly affect the quality and reliability of the device.

Terms and conditions of commercial sale — NXP Semiconductors products are sold subject to the general terms and conditions of commercial sale, as published at <http://www.nxp.com/profile/terms>, unless otherwise agreed in a valid written individual agreement. In case an individual agreement is concluded only the terms and conditions of the respective agreement shall apply. NXP Semiconductors hereby expressly objects to applying the customer's general terms and conditions with regard to the purchase of NXP Semiconductors products by customer.

No offer to sell or license — Nothing in this document may be interpreted or construed as an offer to sell products that is open for acceptance or the grant, conveyance or implication of any license under any copyrights, patents or other industrial or intellectual property rights.

Quick reference data — The Quick reference data is an extract of the product data given in the Limiting values and Characteristics sections of this document, and as such is not complete, exhaustive or legally binding.

Export control — This document as well as the item(s) described herein may be subject to export control regulations. Export might require a prior authorization from competent authorities.

Non-automotive qualified products — Unless this data sheet expressly states that this specific NXP Semiconductors product is automotive qualified, the product is not suitable for automotive use. It is neither qualified nor tested in accordance with automotive testing or application requirements. NXP Semiconductors accepts no liability for inclusion and/or use of non-automotive qualified products in automotive equipment or applications.

In the event that customer uses the product for design-in and use in automotive applications to automotive specifications and standards, customer (a) shall use the product without NXP Semiconductors' warranty of the product for such automotive applications, use and specifications, and (b) whenever customer uses the product for automotive applications beyond NXP Semiconductors' specifications such use shall be solely at customer's own risk, and (c) customer fully indemnifies NXP Semiconductors for any liability, damages or failed product claims resulting from customer design and use of the product for automotive applications beyond NXP Semiconductors' standard warranty and NXP Semiconductors' product specifications.

Translations — A non-English (translated) version of a document is for reference only. The English version shall prevail in case of any discrepancy between the translated and English versions.

21.4 Licenses

Purchase of NXP ICs with NFC technology

Purchase of an NXP Semiconductors IC that complies with one of the Near Field Communication (NFC) standards ISO/IEC 18092 and ISO/IEC 21481 does not convey an implied license under any patent right infringed by implementation of any of those standards.

21.5 Trademarks

Notice: All referenced brands, product names, service names and trademarks are the property of their respective owners.

I²C-bus — logo is a trademark of NXP B.V.

ICODE and I-CODE — are trademarks of NXP B.V.

22. Contact information

For more information, please visit: <http://www.nxp.com>

For sales office addresses, please send an email to: salesaddresses@nxp.com

23. Contents

| | | | | | |
|----------|--|----------|----------|--|----|
| 1 | Introduction | 1 | 8.4.5.2 | SAM connection | 24 |
| 2 | General description | 1 | 8.4.6 | Boundary scan interface | 24 |
| 3 | Features and benefits | 1 | 8.4.6.1 | Interface signals | 25 |
| 4 | Quick reference data | 2 | 8.4.6.2 | Test Clock (TCK) | 25 |
| 5 | Ordering information | 2 | 8.4.6.3 | Test Mode Select (TMS) | 25 |
| 6 | Block diagram | 3 | 8.4.6.4 | Test Data Input (TDI) | 25 |
| 7 | Pinning information | 3 | 8.4.6.5 | Test Data Output (TDO) | 25 |
| 7.1 | Pin description | 4 | 8.4.6.6 | Data register | 26 |
| 8 | Functional description | 5 | 8.4.6.7 | Boundary scan cell | 26 |
| 8.1 | Interrupt controller | 6 | 8.4.6.8 | Boundary scan path | 26 |
| 8.2 | Timer module | 8 | 8.4.6.9 | Boundary Scan Description Language (BSDL) | 27 |
| 8.2.1 | Timer modes | 9 | 8.4.6.10 | Non-IEEE1149.1 commands | 28 |
| 8.2.1.1 | Time-Out- and Watch-Dog-Counter | 9 | 8.5 | Buffer | 29 |
| 8.2.1.2 | Wake-up timer | 9 | 8.5.1 | Overview | 29 |
| 8.2.1.3 | Stop watch | 9 | 8.5.2 | Accessing the FIFO buffer | 29 |
| 8.2.1.4 | Programmable one-shot timer | 9 | 8.5.3 | Controlling the FIFO buffer | 29 |
| 8.2.1.5 | Periodical trigger | 9 | 8.5.4 | Status Information about the FIFO buffer | 29 |
| 8.3 | Contactless interface unit | 10 | 8.6 | Analog interface and contactless UART | 31 |
| 8.3.1 | ISO/IEC15693 functionality | 10 | 8.6.1 | General | 31 |
| 8.3.2 | EPC-UID/UID-OTP functionality | 12 | 8.6.2 | TX transmitter | 31 |
| 8.3.3 | ISO/IEC 18000-3 mode 3/ EPC Class-1 HF functionality | 12 | 8.6.2.1 | Overshoot protection | 33 |
| 8.3.4 | EPC Class-1 HF and ICODE | 12 | 8.6.2.2 | Bit generator | 34 |
| 8.3.4.1 | Data encoding ICODE | 12 | 8.6.3 | Receiver circuitry | 34 |
| 8.4 | Host interfaces | 12 | 8.6.3.1 | General | 34 |
| 8.4.1 | Host interface configuration | 12 | 8.6.3.2 | Block diagram | 35 |
| 8.4.2 | SPI interface | 13 | 8.6.4 | Active antenna concept | 36 |
| 8.4.2.1 | General | 13 | 8.6.5 | Symbol generator | 39 |
| 8.4.2.2 | Read data | 13 | 8.7 | Memory | 39 |
| 8.4.2.3 | Write data | 14 | 8.7.1 | Memory overview | 39 |
| 8.4.2.4 | Address byte | 14 | 8.7.2 | EEPROM memory organization | 40 |
| 8.4.2.5 | Timing Specification SPI | 14 | 8.7.2.1 | Product information and configuration - Page 0 | 41 |
| 8.4.3 | RS232 interface | 15 | 8.7.3 | EEPROM initialization content LoadProtocol | 43 |
| 8.4.3.1 | Selection of the transfer speeds | 15 | 8.8 | Clock generation | 45 |
| 8.4.3.2 | Framing | 16 | 8.8.1 | Crystal oscillator | 45 |
| 8.4.4 | I ² C-bus interface | 18 | 8.8.2 | IntegerN PLL clock line | 45 |
| 8.4.4.1 | General | 18 | 8.8.3 | Low Frequency Oscillator (LFO) | 46 |
| 8.4.4.2 | I ² C Data validity | 18 | 8.9 | Power management | 47 |
| 8.4.4.3 | I ² C START and STOP conditions | 19 | 8.9.1 | Supply concept | 47 |
| 8.4.4.4 | I ² C byte format | 19 | 8.9.2 | Power reduction mode | 47 |
| 8.4.4.5 | I ² C Acknowledge | 20 | 8.9.2.1 | Power-down | 47 |
| 8.4.4.6 | I ² C 7-bit addressing | 20 | 8.9.2.2 | Standby mode | 47 |
| 8.4.4.7 | I ² C-register write access | 21 | 8.9.2.3 | Modem off mode | 47 |
| 8.4.4.8 | I ² C-register read access | 21 | 8.9.3 | Low-Power Card Detection (LPCD) | 48 |
| 8.4.4.9 | I ² CL-bus interface | 22 | 8.9.4 | Reset and start-up time | 48 |
| 8.4.5 | SAM interface I ² C | 23 | 8.10 | Command set | 49 |
| 8.4.5.1 | SAM functionality | 23 | 8.10.1 | General | 49 |
| | | | 8.10.2 | Command set overview | 49 |

continued >>

| | | | | | |
|-----------|---|-----------|----------|--|----|
| 8.10.3 | Command functionality | 50 | 9.7.2.13 | T2CounterValHi | 74 |
| 8.10.3.1 | Idle command | 50 | 9.7.2.14 | T2CounterValLoReg | 74 |
| 8.10.3.2 | LPCD command | 50 | 9.7.2.15 | T3Control | 74 |
| 8.10.3.3 | AckReq command | 50 | 9.7.2.16 | T3ReloadHi | 75 |
| 8.10.3.4 | Receive command | 50 | 9.7.2.17 | T3ReloadLo | 75 |
| 8.10.3.5 | Transmit command | 50 | 9.7.2.18 | T3CounterValHi | 76 |
| 8.10.3.6 | Transceive command | 51 | 9.7.2.19 | T3CounterValLo | 76 |
| 8.10.3.7 | WriteE2 command | 51 | 9.7.2.20 | T4Control | 76 |
| 8.10.3.8 | WriteE2PAGE command | 51 | 9.7.2.21 | T4ReloadHi | 77 |
| 8.10.3.9 | ReadE2 command | 51 | 9.7.2.22 | T4ReloadLo | 77 |
| 8.10.3.10 | LoadReg command | 51 | 9.7.2.23 | T4CounterValHi | 78 |
| 8.10.3.11 | LoadProtocol command | 51 | 9.7.2.24 | T4CounterValLo | 78 |
| 8.10.3.12 | GetRNR command | 52 | 9.8 | Transmitter configuration registers | 78 |
| 8.10.3.13 | SoftReset command | 52 | 9.8.1 | TxMode | 78 |
| 9 | SLRC610 registers | 54 | 9.8.2 | TxAmp | 79 |
| 9.1 | Register bit behavior | 54 | 9.8.3 | TxCon | 79 |
| 9.2 | Command configuration | 57 | 9.8.4 | Txl | 80 |
| 9.2.1 | Command | 57 | 9.9 | CRC configuration registers | 80 |
| 9.3 | SAM configuration register | 57 | 9.9.1 | TxCrcPreset | 80 |
| 9.3.1 | HostCtrl | 57 | 9.9.2 | RxCrcCon | 81 |
| 9.4 | FIFO configuration register | 58 | 9.10 | Transmitter configuration registers | 82 |
| 9.4.1 | FIFOControl | 58 | 9.10.1 | TxDataNum | 82 |
| 9.4.2 | WaterLevel | 58 | 9.10.2 | TxSym10BurstLen | 83 |
| 9.4.3 | FIFOLength | 60 | 9.10.3 | TxWaitCtrl | 83 |
| 9.4.4 | FIFOData | 60 | 9.10.4 | TxWaitLo | 85 |
| 9.5 | Interrupt configuration registers | 60 | 9.11 | FrameCon | 85 |
| 9.5.1 | IRQ0 register | 61 | 9.12 | Receiver configuration registers | 86 |
| 9.5.2 | IRQ1 register | 61 | 9.12.1 | RxSofD | 86 |
| 9.5.3 | IRQ0En register | 62 | 9.12.2 | RxCtrl | 86 |
| 9.5.4 | IRQ1En | 62 | 9.12.3 | RxWait | 87 |
| 9.6 | Contactless interface configuration registers | 63 | 9.12.4 | RxThreshold | 87 |
| 9.6.1 | Error | 63 | 9.12.5 | Rcv | 87 |
| 9.6.2 | Status | 64 | 9.12.6 | RxAna | 88 |
| 9.6.3 | RxBitCtrl | 65 | 9.13 | Clock configuration | 89 |
| 9.6.4 | RxColl | 67 | 9.13.1 | SerialSpeed | 89 |
| 9.7 | Timer configuration registers | 68 | 9.13.2 | LFO_Trimm | 90 |
| 9.7.1 | TControl | 68 | 9.13.3 | PLL_Ctrl Register | 90 |
| 9.7.2 | T0Control | 68 | 9.13.4 | PLLDiv_Out | 91 |
| 9.7.2.1 | T0ReloadHi | 69 | 9.14 | Low-power card detection configuration registers | 92 |
| 9.7.2.2 | T0ReloadLo | 69 | 9.14.1 | LPCD_QMin | 92 |
| 9.7.2.3 | T0CounterValHi | 70 | 9.14.2 | LPCD_QMax | 92 |
| 9.7.2.4 | T0CounterValLo | 70 | 9.14.3 | LPCD_IMin | 93 |
| 9.7.2.5 | T1Control | 70 | 9.14.4 | LPCD_Result_I | 93 |
| 9.7.2.6 | T1ReloadHi | 71 | 9.14.5 | LPCD_Result_Q | 93 |
| 9.7.2.7 | T1ReloadLo | 71 | 9.15 | Pin configuration | 94 |
| 9.7.2.8 | T1CounterValHi | 72 | 9.15.1 | PinEn | 94 |
| 9.7.2.9 | T1CounterValLo | 72 | 9.15.2 | PinOut | 94 |
| 9.7.2.10 | T2Control | 72 | 9.15.3 | PinIn | 95 |
| 9.7.2.11 | T2ReloadHi | 73 | 9.15.4 | SigOut | 95 |
| 9.7.2.12 | T2ReloadLo | 73 | 9.16 | Version register | 96 |

continued >>

9.16.1 Version 96

10 Limiting values. 97

11 Recommended operating conditions. 97

12 Thermal characteristics 97

13 Characteristics. 97

13.1 Timing characteristics 100

14 Application information. 102

14.1 Antenna design description 102

14.1.1 EMC low pass filter 102

14.1.2 Antenna matching 103

14.1.3 Receiving circuit 103

14.1.4 Antenna coil 104

15 Package outline 105

16 Handling information. 106

17 Packing information 106

18 Abbreviations. 110

19 References 111

20 Revision history. 112

21 Legal information. 113

21.1 Data sheet status 113

21.2 Definitions 113

21.3 Disclaimers 113

21.4 Licenses 114

21.5 Trademarks. 114

22 Contact information. 114

23 Contents 115

Please be aware that important notices concerning this document and the product(s) described herein, have been included in section 'Legal information'.

© NXP B.V. 2014.

All rights reserved.

For more information, please visit: <http://www.nxp.com>

For sales office addresses, please send an email to: salesaddresses@nxp.com

Date of release: 6 February 2014
227634